

Installationsanleitung

ST SA Flip II 55" | Art.-Nr.: 5787

ST SA Flip II 65" | Art.-Nr.: 5788

DE Installationsanleitung

GB Installation manual

FR Guide d'installation

NL Installatievoorschrift

ES Guía de instalación

SE Installationsanvisning

TR Yükleme Rehberi

RU инструкция по установке

CN 安装指南

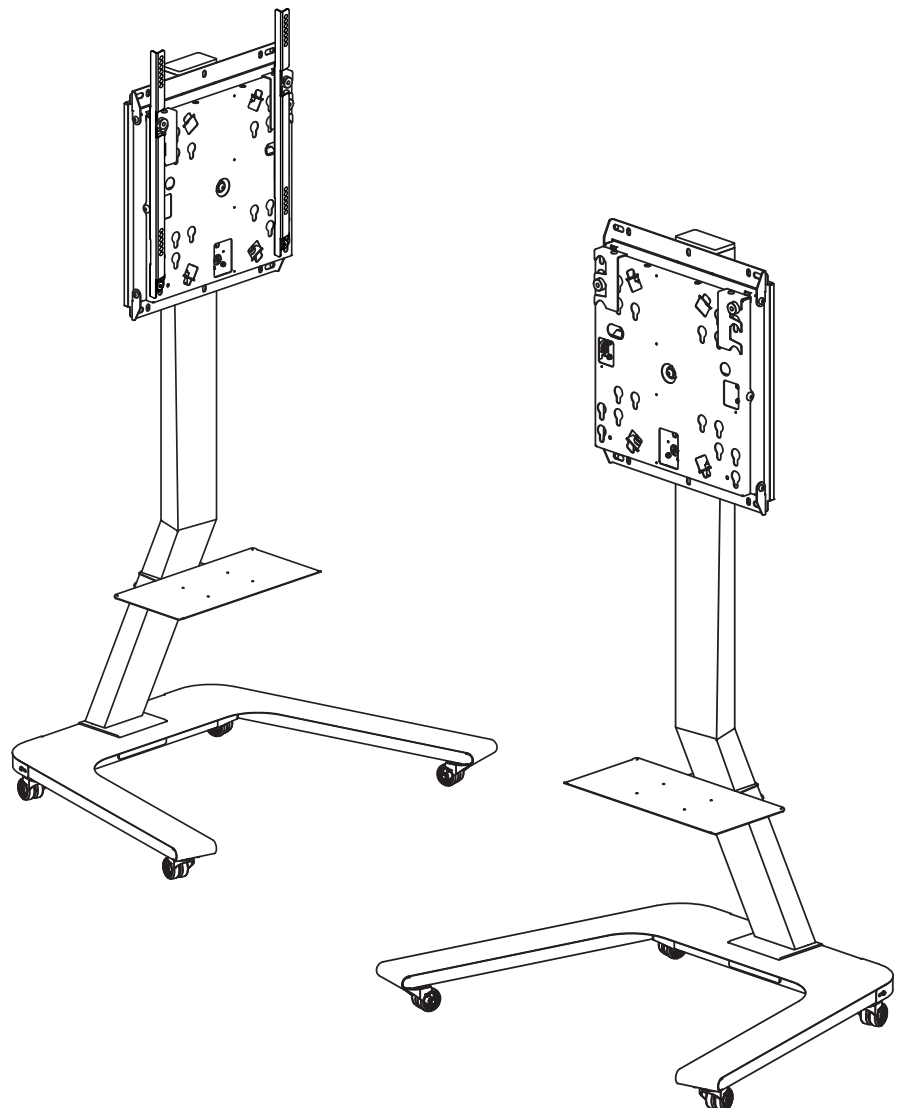

DE

Achtung!

Technische Geräte stellen einen beträchtlichen Wert dar. Sie sollten daher bei der Installation vorsichtig mit den Komponenten umgehen und diese bei Bedarf schützen.

Auch sollte, falls nötig, der Installtionsbereich abgesichert werden. Herabfallende Teile können zu Verletzungen und Materialschäden führen.

Die im Lieferumfang enthaltenen Materialien sind unter Umständen nicht für die speziellen Gegebenheiten am Installationsort geeignet. Bitte prüfen Sie dies vorab und ersetzen Sie diese bei Bedarf durch geeignete Materialien.

Falls Sie Bezüglich der Installation des Produkts unsicher sind oder noch Fragen haben wenden Sie sich an uns oder anderes ausgebildetes Fachpersonal.

GB

Caution!

Technical devices are of considerable value. You should therefore handle the components carefully during installation and protect them if necessary.

If necessary, the installation area should also be secured. Falling parts can cause injuries and material damage.

The materials included in the scope of delivery may not be suitable for the special conditions at the installation site. Please check this in advance and replace it with suitable materials if necessary.

If you are unsure about the installation of the product or have any questions, please contact us or other trained specialists.

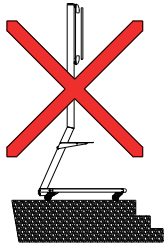

Nicht auf geneigten Böden verwenden.

Do not use the stand on sloping floors.

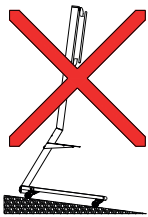

Nicht in der Nähe von Treppen oder Absätzen verwenden.

Do not use the stand near stairs or floors with gradients.

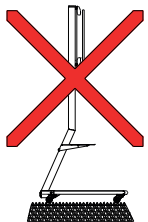

Nicht für den Außenbereich geeignet. Nicht auf unebenene, rauhen Böden verwenden, da dies die Rollen beschädigen kann.

Do not use the stand on external or rough floors that could damage the wheels.

Die Installation sollte durch fachkundiges Personal durchgeführt werden.

The installation should be performed by competent personnel.

Lieferumfang | Scope of delivery

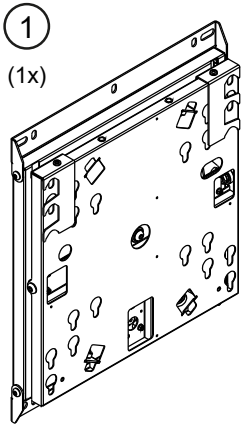

1
(1x)

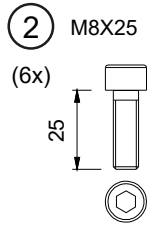

2 M8X25
(6x)

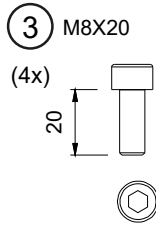

3 M8X20
(4x)

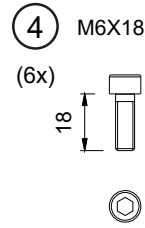

4 M6X18
(6x)

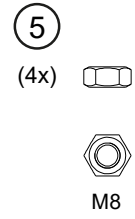

5
(4x)

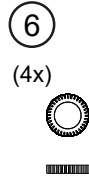

6
(4x)

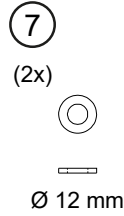

7
(2x)

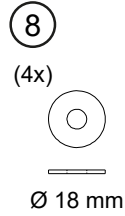

8
(4x)

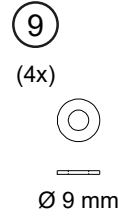

9
(4x)

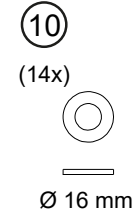

10
(14x)

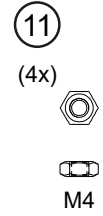

11
(4x)

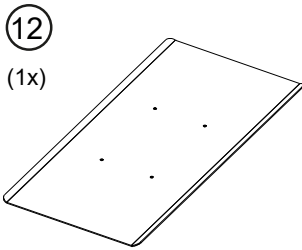

12
(1x)

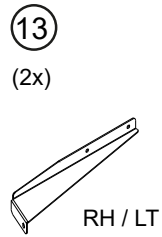

13
(2x)

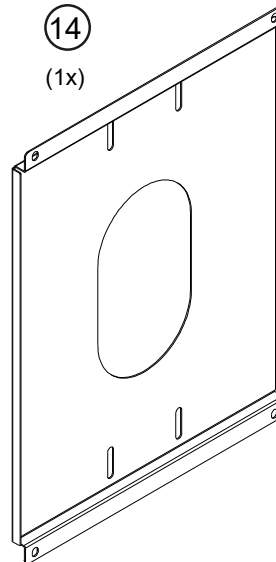

14
(1x)

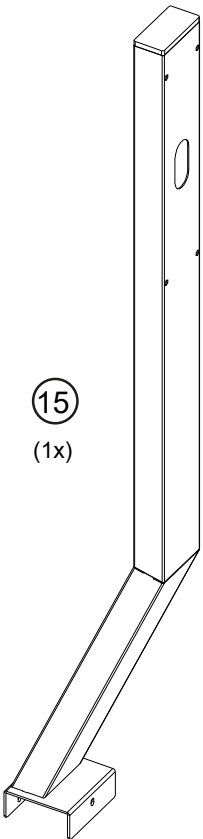

15
(1x)

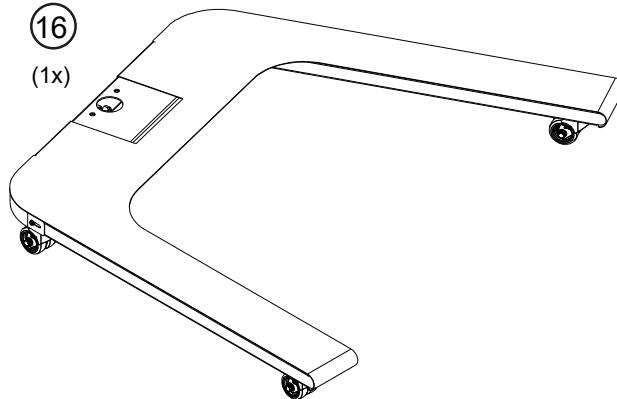

16
(1x)



17
(2x)

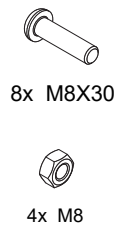

NUR FÜR ART.-NR.: 8788
ONLY FOR ITEM NO.: 8788

Ansicht von oben | Top view

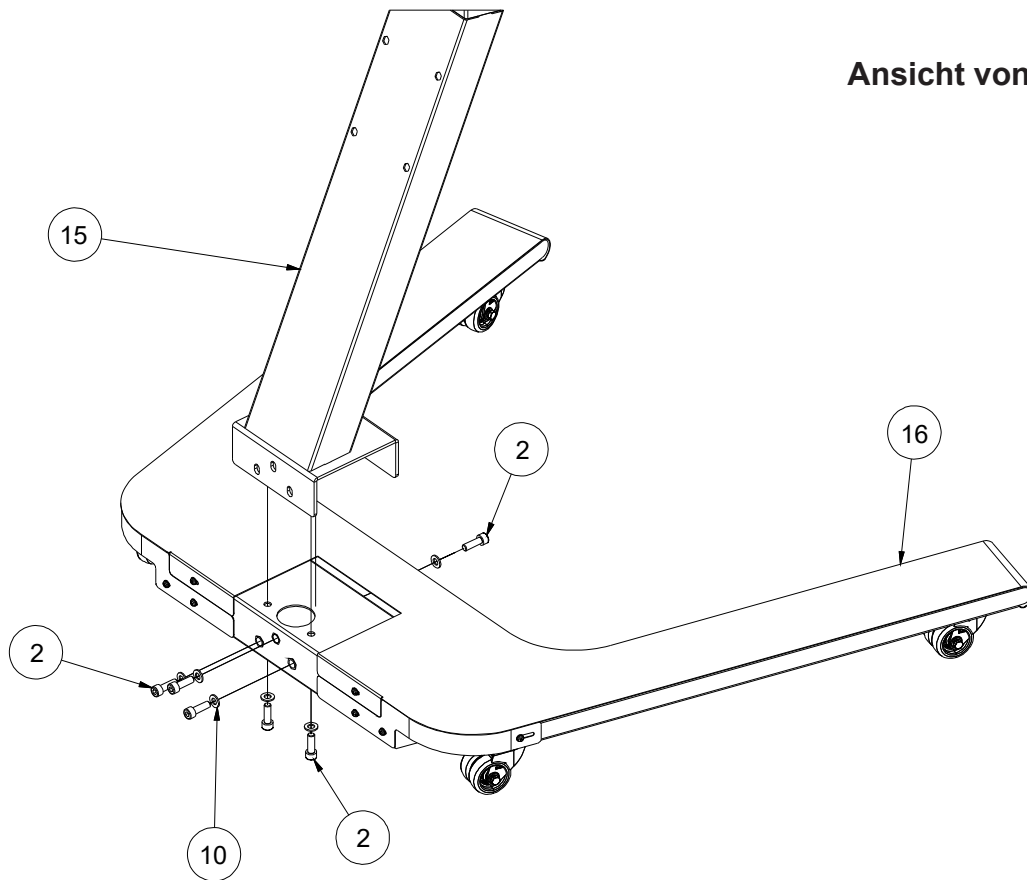

Ansicht von unten | Bottom view

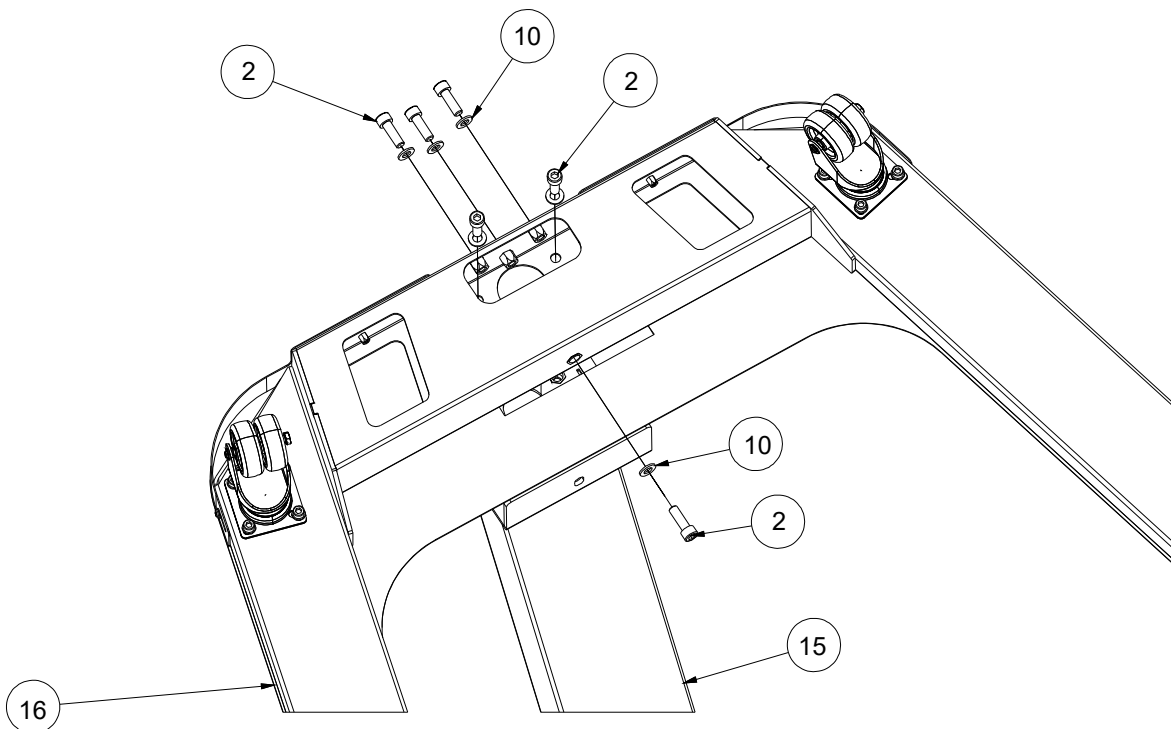

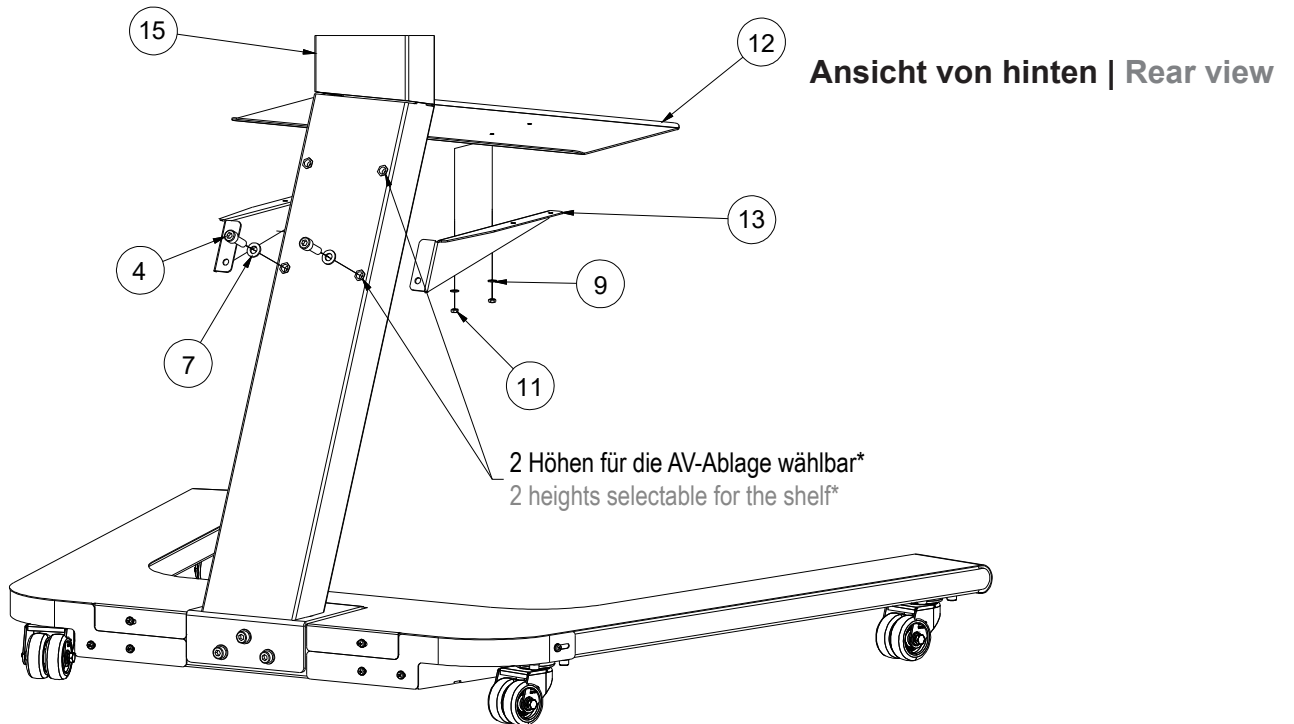

*Bitte beachten! Die AV-Ablage kann beim ST SA Flip II 65" nur in der unteren Position verwendet werden.

*Please note! The AV shelf can only be used in the lower position with the ST SA Flip II 65".

Ansicht von vorne | Front view

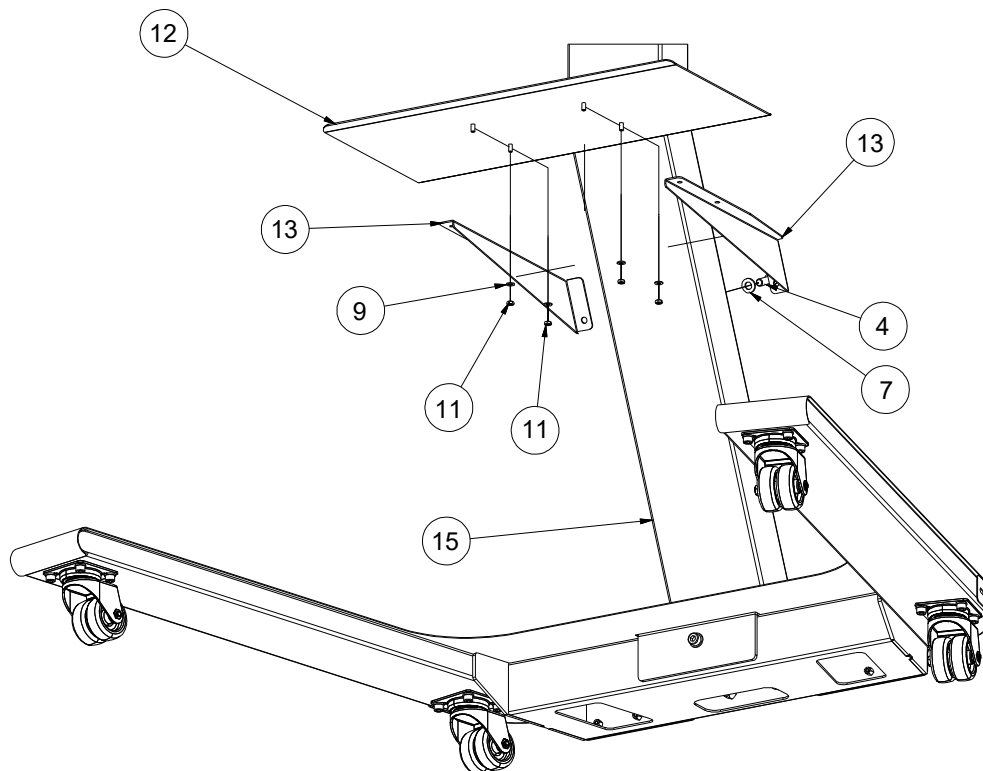

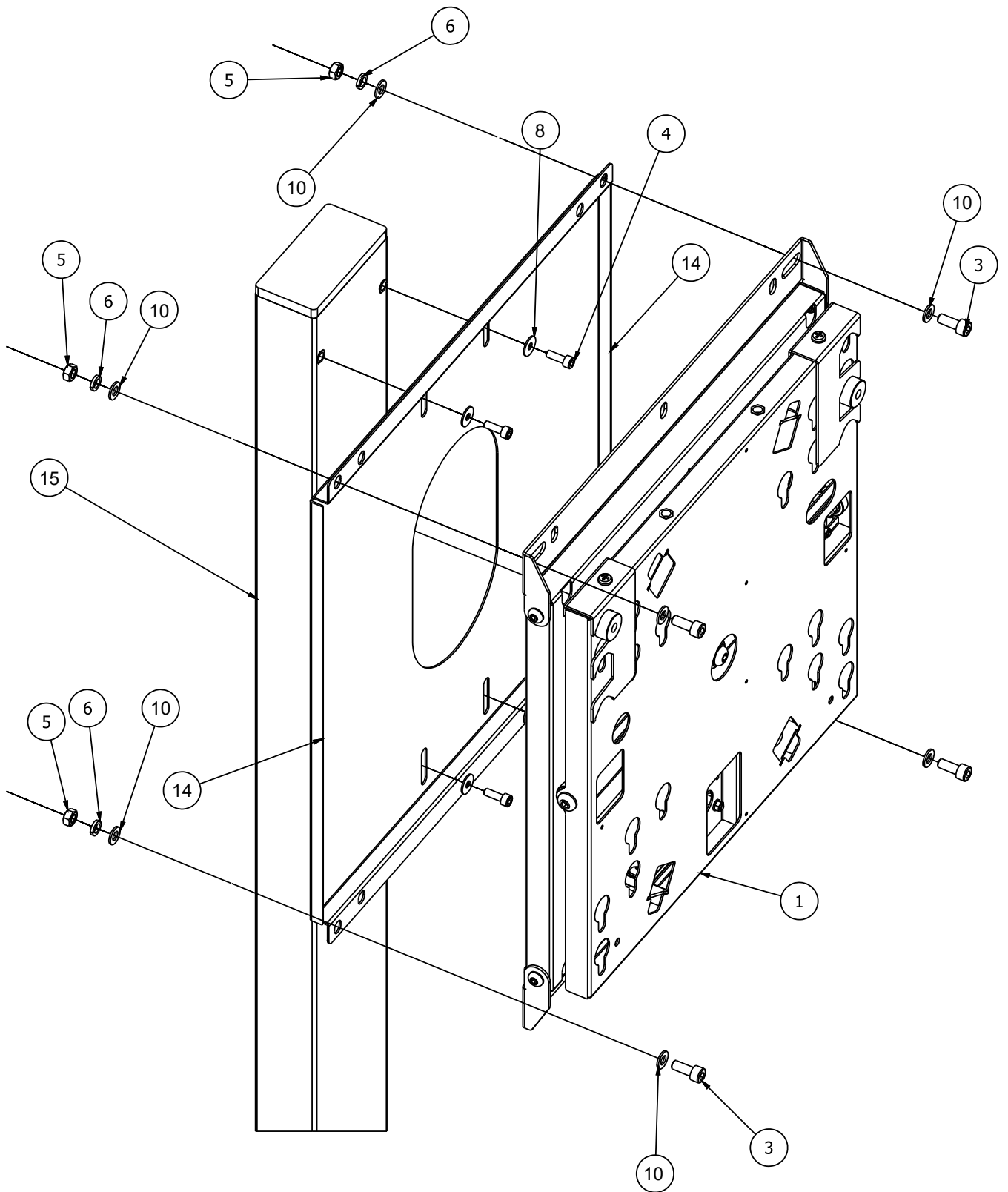

4a Installation der Haltebolzen | Installation of the fixing bolts | ST SA Flip II 55"

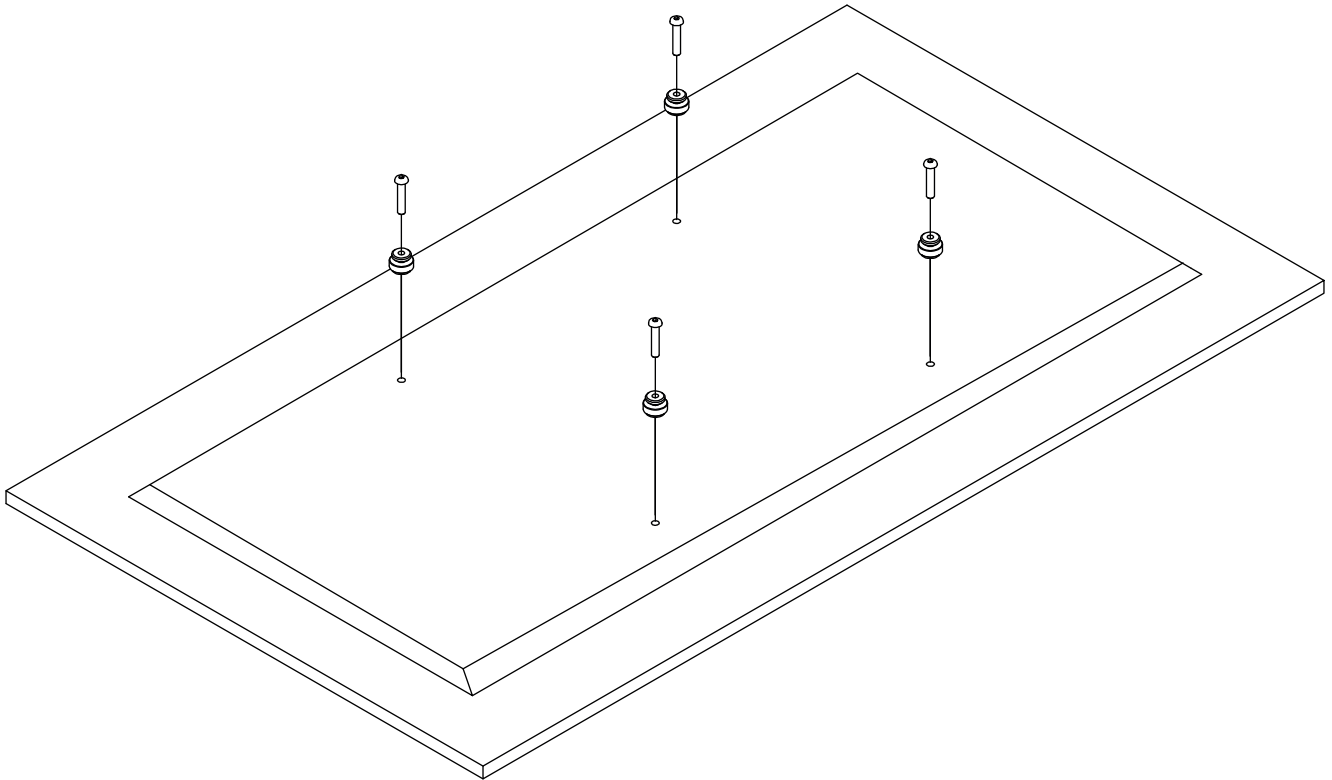

M8x45

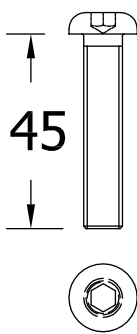

M8x55

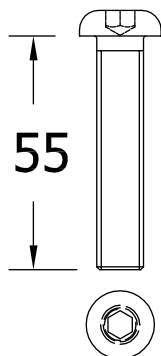

Haltebolzen, tiefenjustierbar
Adjustable ring

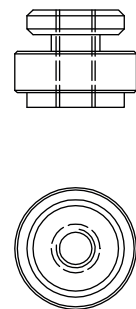

Länge der Schraube abhängig von
der Lochtiefe des TV.
Bitte vorher messen.

Length of the screw depends on
the hole depth of the TV.
Please measure in advance.

4b Installation der Haltebolzen | Installation of the fixing bolts | ST SA Flip II 65“

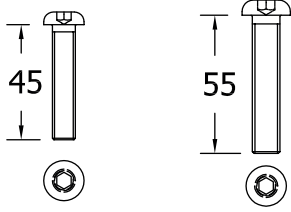
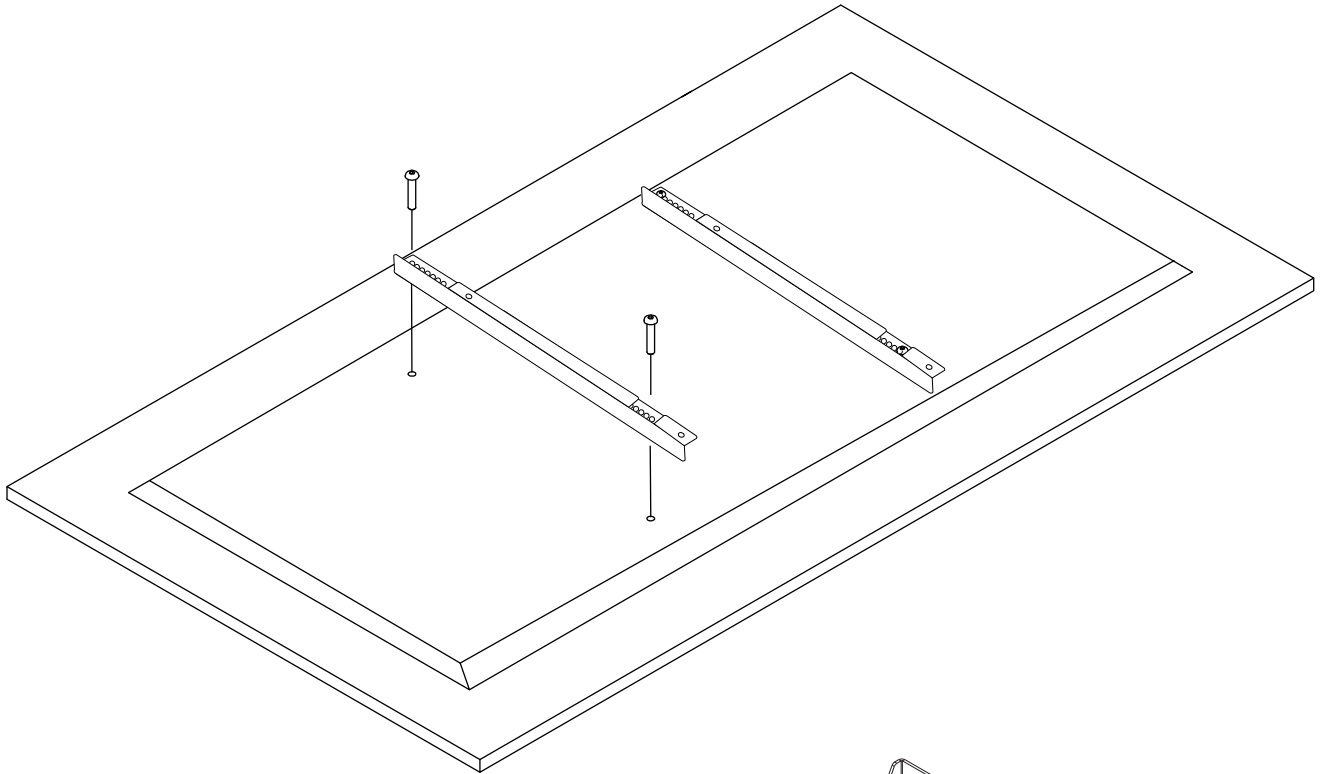

M8x45

M8x55

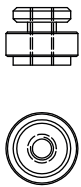

Haltebolzen, tiefenjustierbar
Adjustable ring

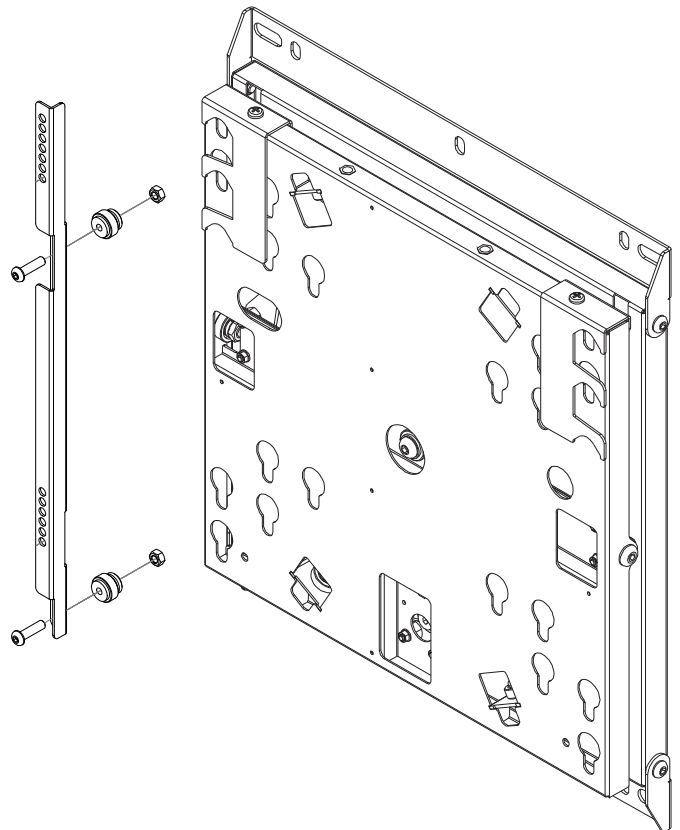

**Länge der Schraube abhängig von
der Lochtiefe des TV.
Bitte vorher messen.**

**Length of the screw depends on
the hole depth of the TV.
Please measure in advance.**

5 Demontage des Sicherungsbügels | Disassembly of the securing bracket

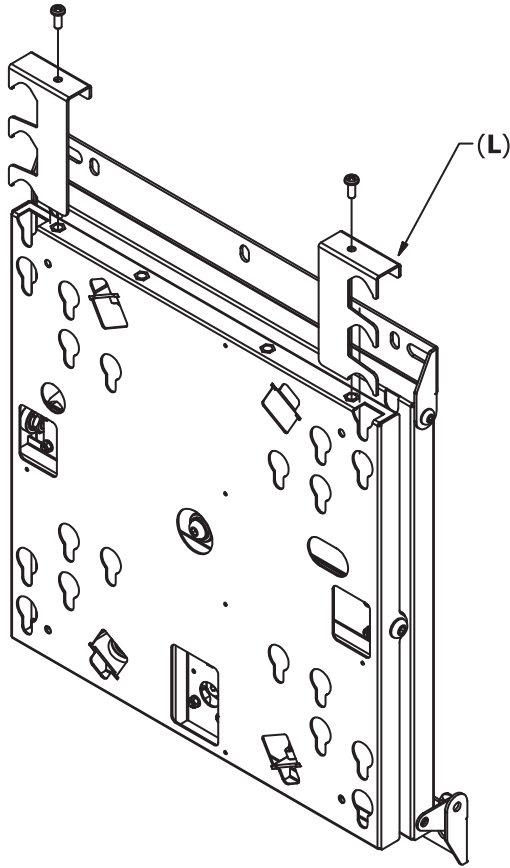

Entfernen Sie den Sicherheitsbügel (L).

Remove the safety bracket (L).

6 Neigungseinstellung | Tilt settings

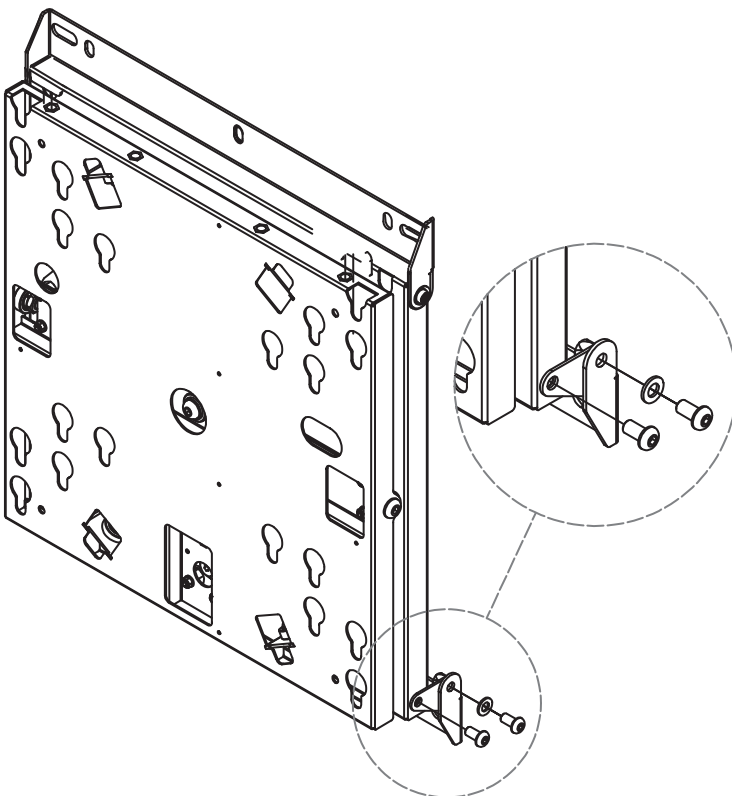

Entfernen Sie die Schrauben und die Unterlegscheiben.
Montieren Sie die 2 Kippplatten (B).
Befestigen Sie diese mit den Schrauben und den Unterlegscheiben.

Remove the screws and the washers.
Assemble the 2 tilting plates (B).
Fix them with the screws and the washers.

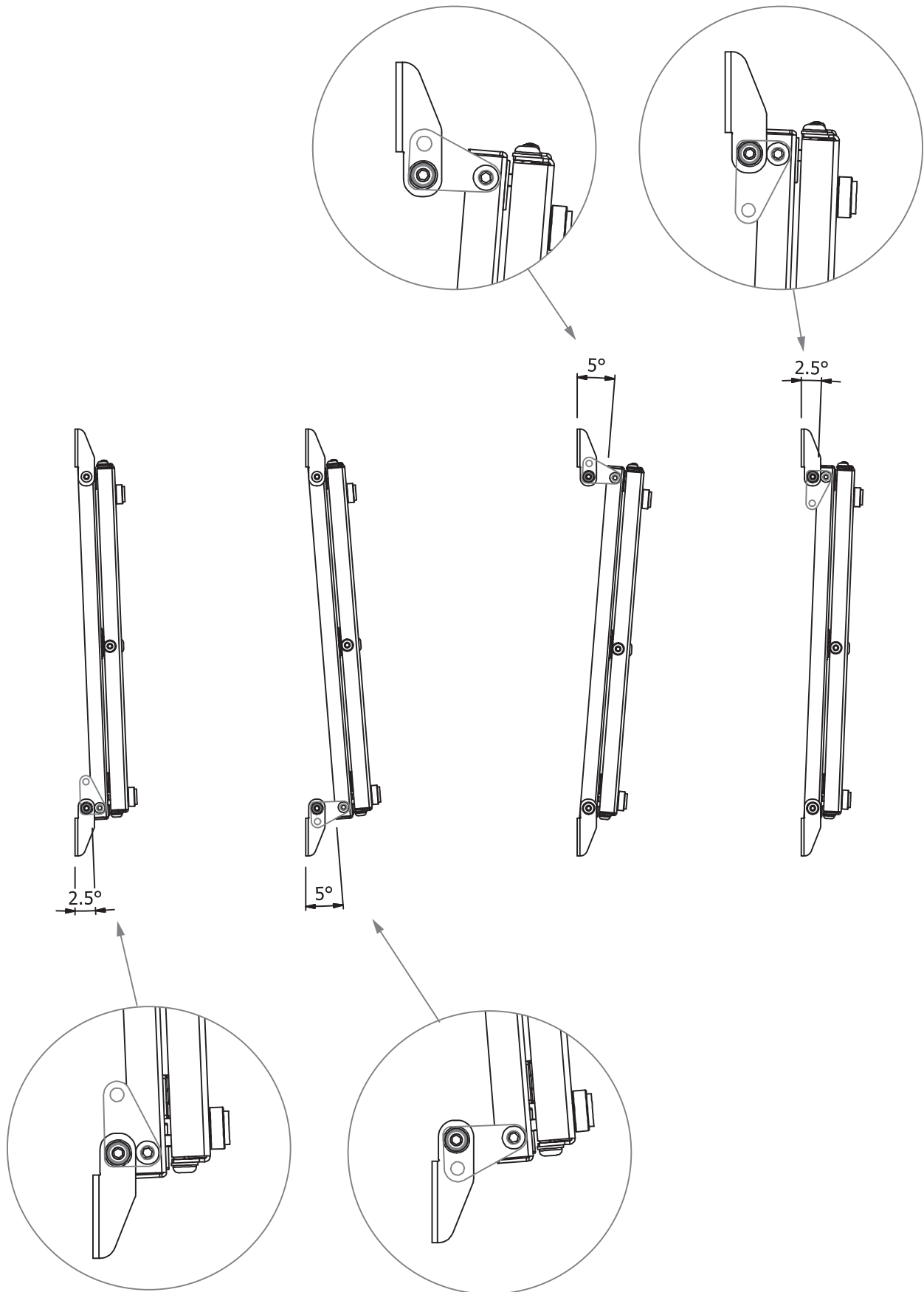

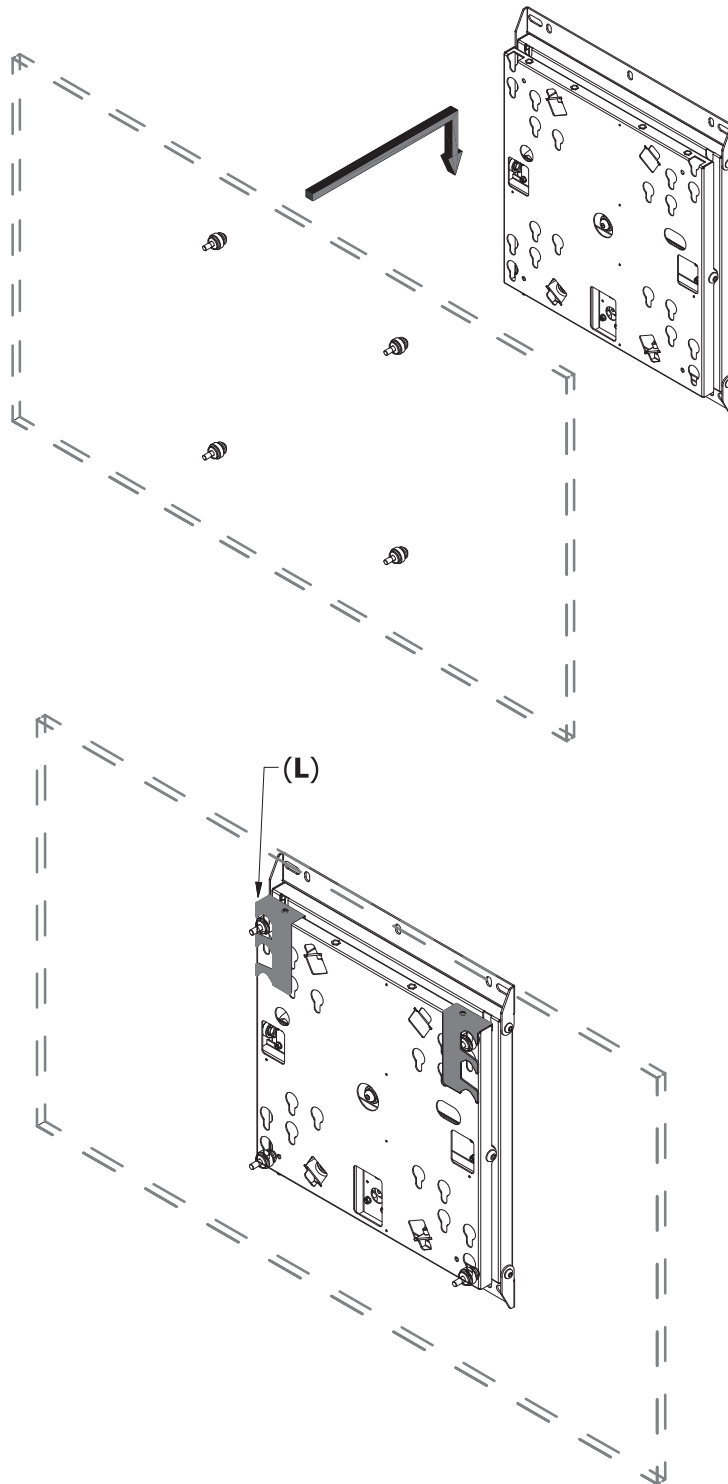

Hängen Sie den Bildschirm ein. Bitte beachten! Diesen Arbeitsschritt bitte zu zweit ausführen. Stellen Sie sicher, dass die Bolzen richtig in die Schlüssellöcher eingehängt wurden. Setzen Sie die Sicherungsbügel wieder ein und schrauben sie diese fest.

Hang up the screen. Please note! Please perform this work step in pairs. Make sure that the bolts are correctly inserted into the keyholes. Replace the securing brackets and screw them tight.

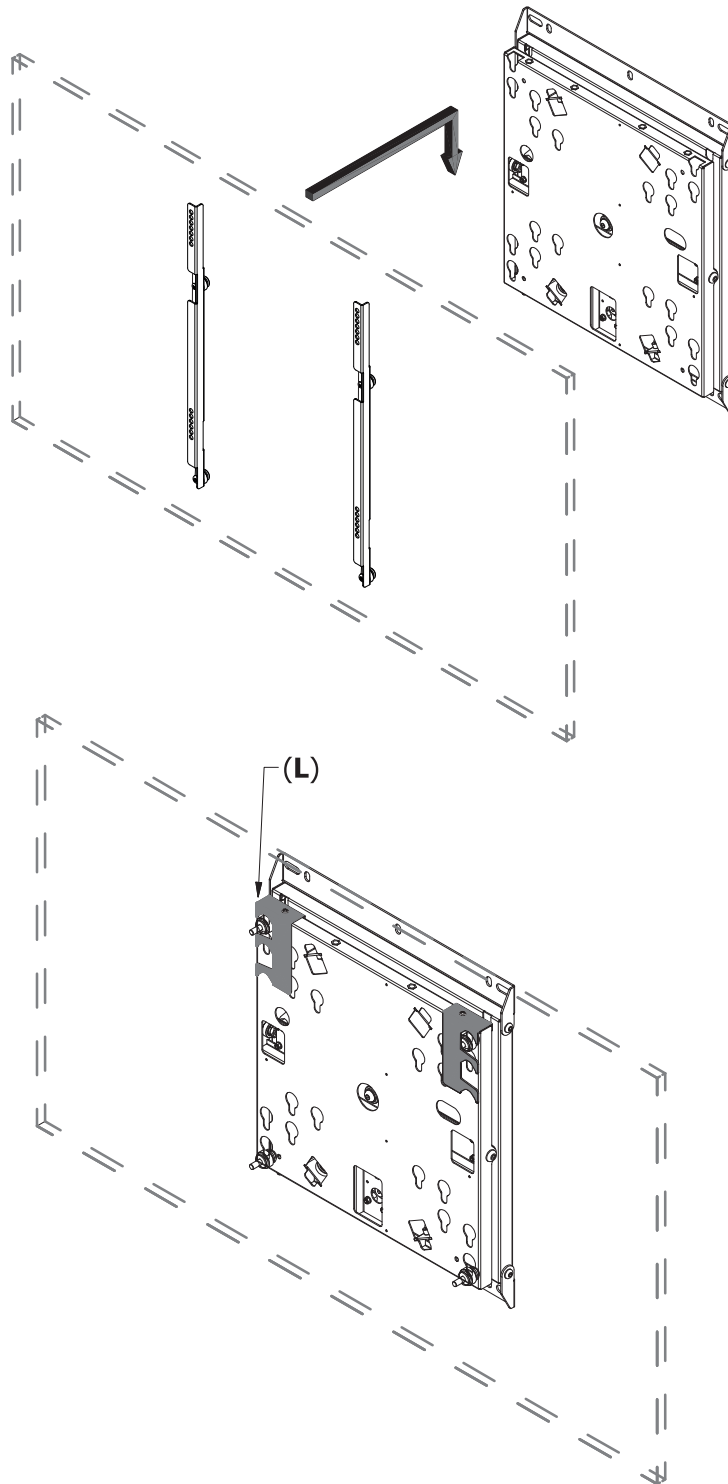

Hängen Sie den Bildschirm ein. Bitte beachten! Diesen Arbeitsschritt bitte zu zweit ausführen. Stellen Sie sicher, dass die Bolzen richtig in die Schlüssellöcher eingehängt wurden. Setzen Sie die Sicherungsbügel wieder ein und schrauben sie diese fest.

Hang up the screen. Please note! Please perform this work step in pairs. Make sure that the bolts are correctly inserted into the keyholes. Replace the securing brackets and screw them tight.

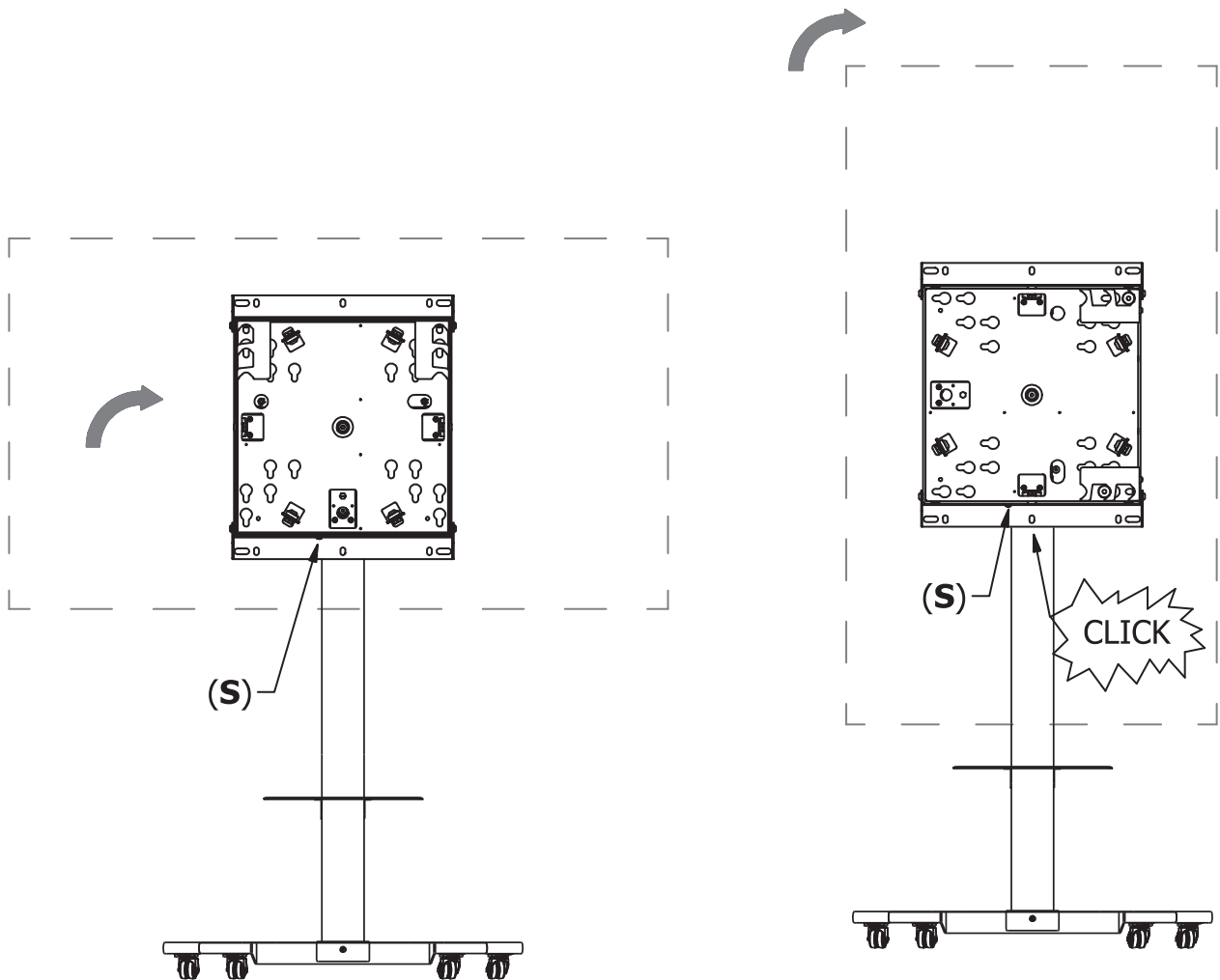

Probieren Sie die Drehung mehrmals aus und vergewissern Sie sich, dass der Bildschirm mit den Sicherungsbügeln (L) sicher verriegelt ist. Erhöhen oder verringern Sie bei Bedarf die Federkraft durch Verstellen der Schraube (S).

Try the rotation several times and make sure the screen is securely locked with the safety brackets (L)
If necessary, increase or decrease the force of the spring by adjusting the screw (S).

Abmessungen | Dimensions | ST SA Flip II 55"

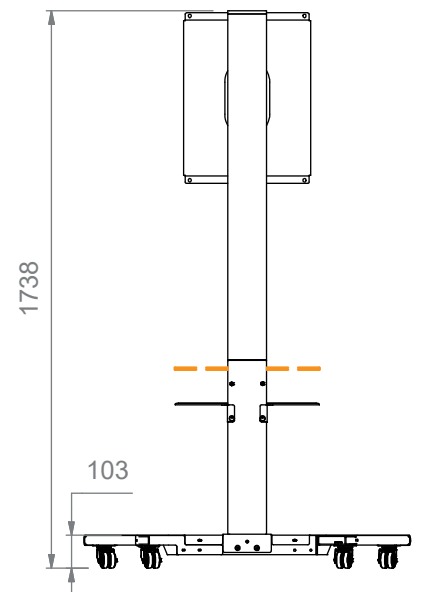
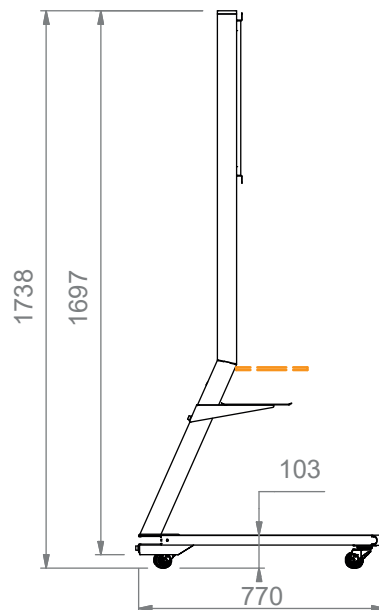
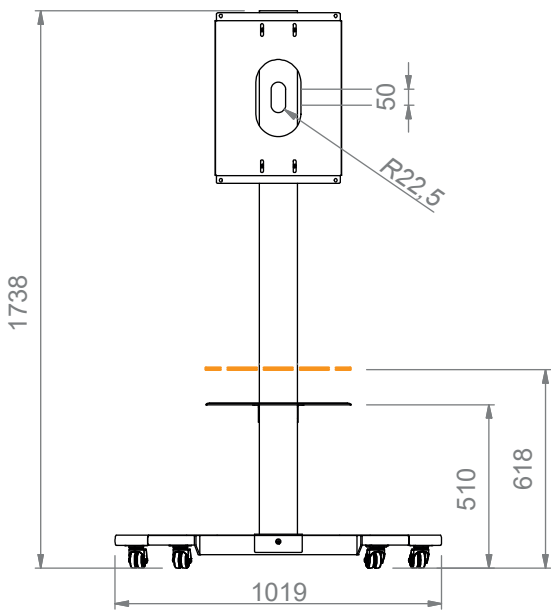
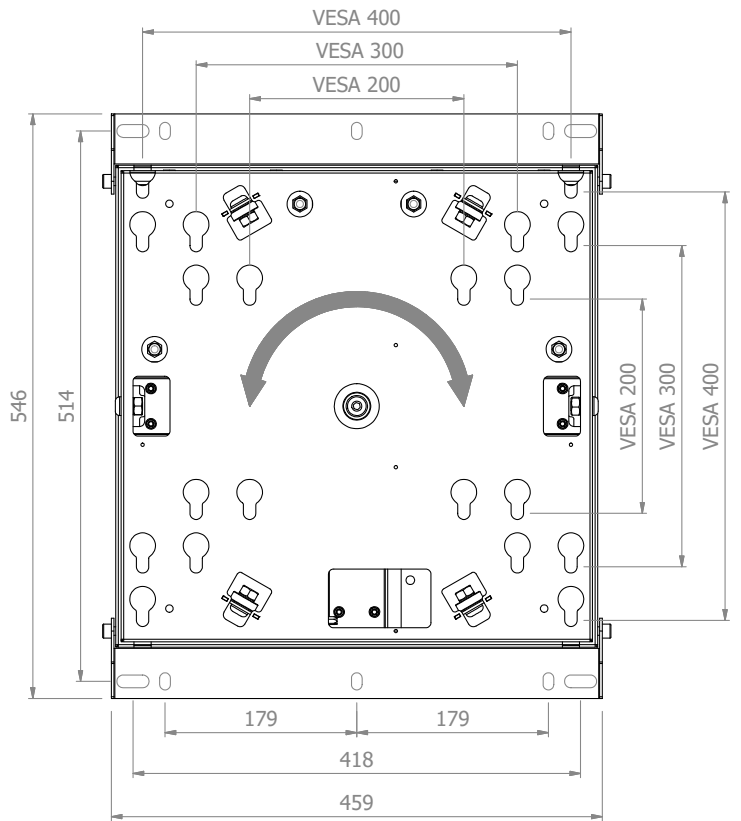
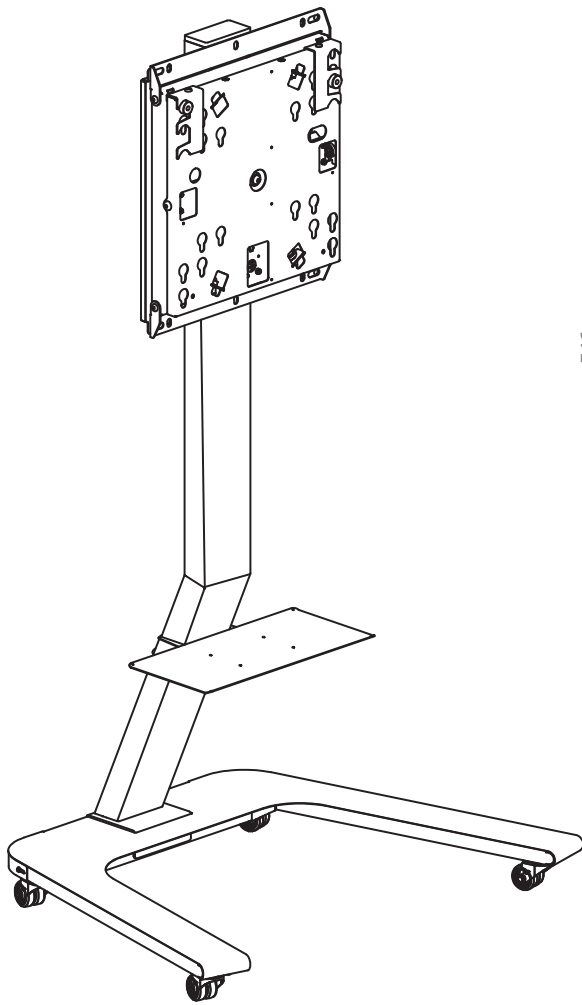

Abmessungen | Dimensions | ST SA Flip II 65"

