

FPZ-670



Mounting Pattern
200 x 200mm



Max Load
200lb (90.7kg)
per display

Flat Panel Floor Stand

FOR UP TO 90" DISPLAYS

The Peerless-AV® FPZ-670 Flat Panel Floor Stand is designed to support up to two 90" displays, mounted back-to-back, in either landscape or portrait orientation. The attractive, yet robust and functional, stand is ideal for a wide variety of applications and settings from boardrooms, training rooms and lobbies, to classrooms, auditoriums and exhibition halls. Its appearance is complemented by a sturdy base, with a concealed compartment to house media players and surge protectors, while its internal cable management system conceals cables and cords, delivering a clean look for any application.

- VESA® 200 x 200mm compliant
- Supports additional VESA® patterns with PLP display adaptor (sold separately)
- Hook-on design allows display to rest in place while display is being secured
- Portrait or landscape display orientation
- Height adjustable on 72" (1829mm) poles



SINGLE OR BACK-TO-BACK DISPLAYS

Multiple configurations for flat panel displays up to 90"

INTEGRATED CABLE MANAGEMENT

Protects, contains and conceals cables for a clean, professional installation



MEDIA PLAYER STORAGE

Designed to conceal media player and surge protectors



RoHS
2002/95/EC

✉ info@peerless-av.com

🌐 peerless-av.com

peerless-AV®
Driving Technology Through Innovation

FPZ-670 Flat Panel Floor Stand for up to 90" Displays

Product Specifications

	DIMENSIONS (W X H X D)	PRODUCT WEIGHT	LOAD CAPACITY	FINISH	AVAILABLE COLORS
FPZ-670	39.94" x 72.33" x 48.00" (1015 x 1837 x 1219mm)	194.4lb (88.1kg)	400lb (181.4kg) total 200lb (90.7kg) per display (Up to two displays)	Powder Coat	Black

Package Specifications

	PACKAGE SIZE (W x H x D)	PACKAGE SHIP WEIGHT	PACKAGE UPC CODE	PACKAGE CONTENTS	UNITS IN PACKAGE
FPZ-670	Box 1: 50" x 8.75" x 41.625" (1270 x 222 x 1057mm)	Box 1: 165lb (74.8kg)	735029257844	Base, Base Cover, 2 Columns, Vesa® 200 X 200mm Adaptor Plates & Mounting Hardware	1
	Box 2 & 3: 72" x 4" x 4" (1830 x 101 x 101mm)	Box 2 & 3: 17.6lb (7.9kg)			

Accessories

RM12C: Rotational Mount Interface
MIS735: Dual-Display Cartridge
PLP-V models: Dedicated Adaptor Plates

ACC-M1015: Required for PLP-UNM or PLP-UNL Attachment
PLP-UNM: Universal I-Shaped Adaptor for 22" to 50" Displays
PLP-UNL: Universal I-Shaped Adaptor for 32" to 90" Displays

All dimensions = inch (mm)

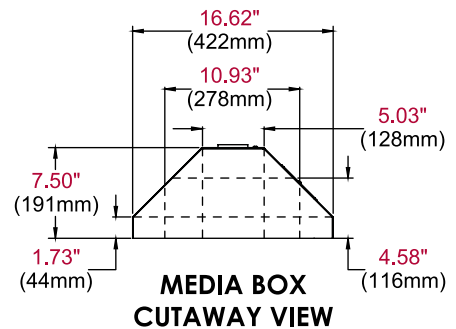
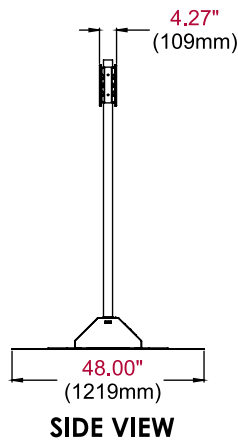
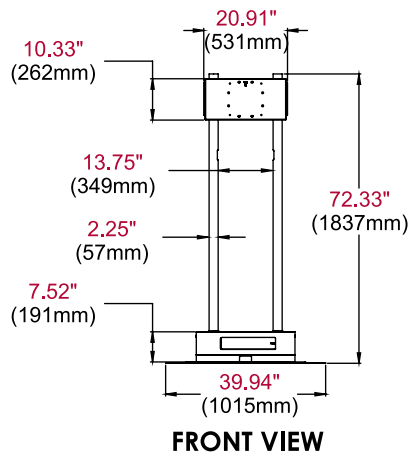
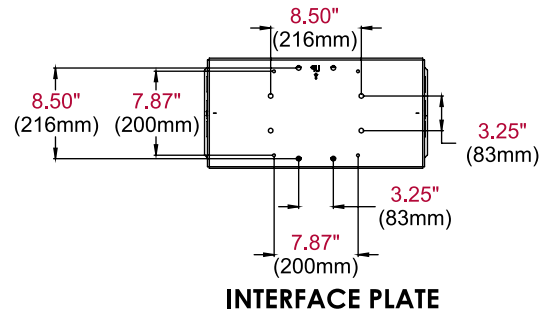
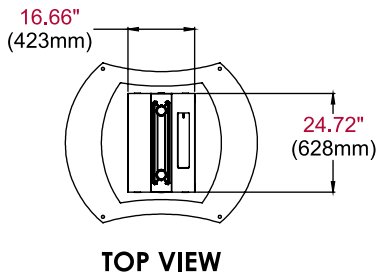

Architect Specifications

The Flat Panel Floor Stand shall be a Peerless-AV model FPZ-670 and shall be located where indicated on the plans. Assembly and installation shall be done according to instructions provided by the manufacturer.

Visit peerless-av.com to see the complete line of AV solutions from Peerless-AV, including outdoor displays, wireless, kiosks, digital audio, display mounts, projector mounts, carts/stands, and a full assortment of accessories.

Peerless-AV
 2300 White Oak Circle
 Aurora, IL 60502 USA
(800) 865-2112
(630) 375-5100
Fax: (800) 359-6500

Peerless-AV EMEA
 Unit 3 Watford Interchange
 Colonial Way, Watford
 Herts, WD24 4WP
 United Kingdom
+44 (0) 1923 200100
Fax: +44 (0) 1923 200101

Peerless-AV Latin America
 Ave de las Industrias 413
 Parque Industrial Escobedo
 Escobedo, N.L.,
 Mexico 66062
+52 (81) 8384-8300
Fax: +52 (81) 8384-8360

