

Kurz-Bedienungsanleitung

Lieferumfang

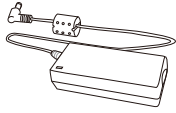

Lautsprecher



Netzteil

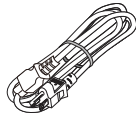

Netzkabel



3,5 mm Audiokabel

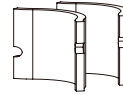

Schaumstoff

Achtung



Tischinstallation

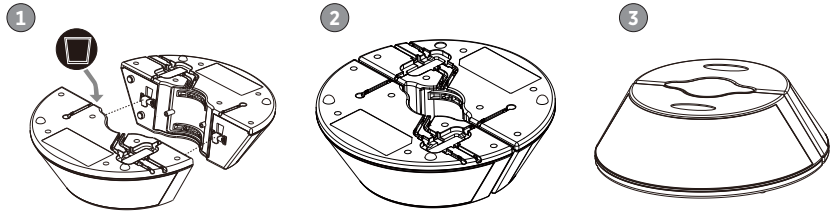

Deckeninstallation

1. Bringen Sie den Schaumstoff an der Innenseite an

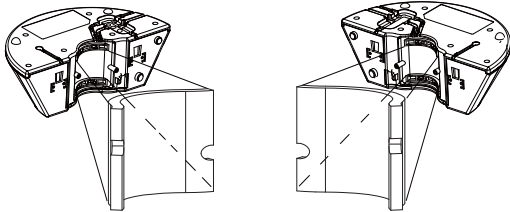

2. Verbinden Sie die beiden Lautsprecher durch die Metallklammer, so dass die Halterung umschlossen wird.

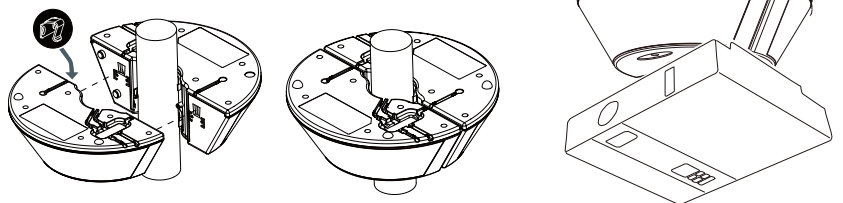

Verbindung zum Projektor

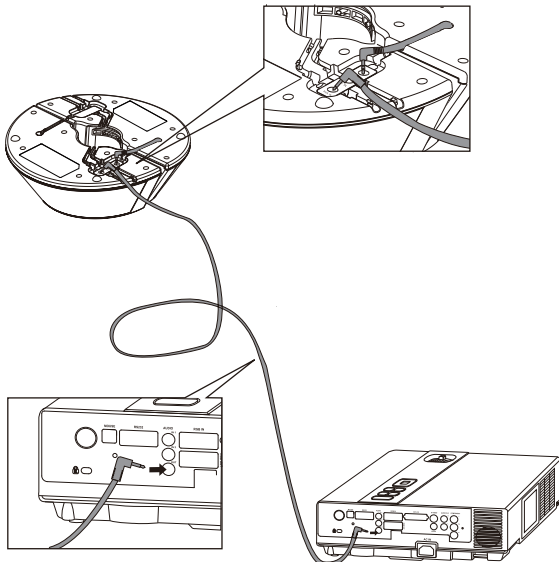

Verbindung Netzkabel

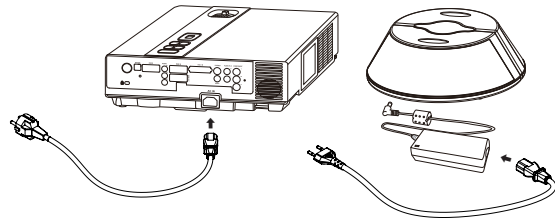

Ref. No. 8705 000 029

Quick start guide

Package contents



Speaker

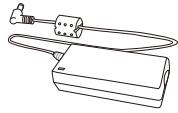

AC adapter

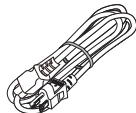

Power cord



3.5 mm audio cable

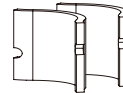

Sponge

Attention



Desktop installation

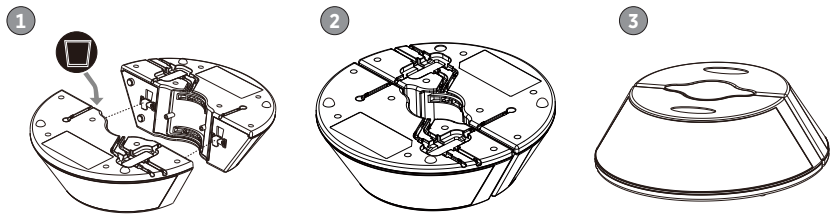

Ceiling-mount installation

- 1 Put the sponge on the inner side of speaker.

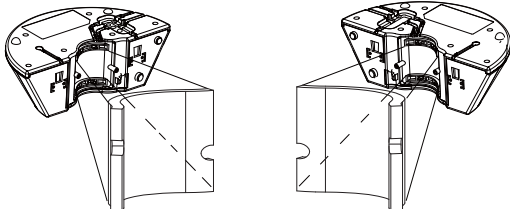

- 2 Connect main engine and auxiliary engine by metal hook and fix on the hanging bracket.

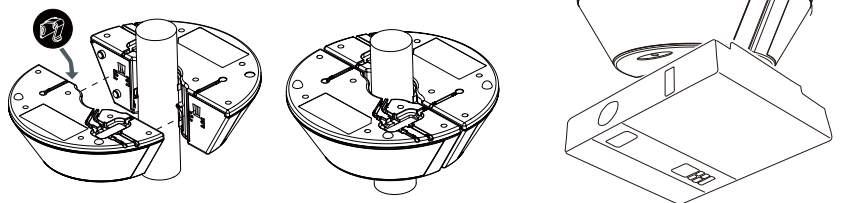

Connecting a projector

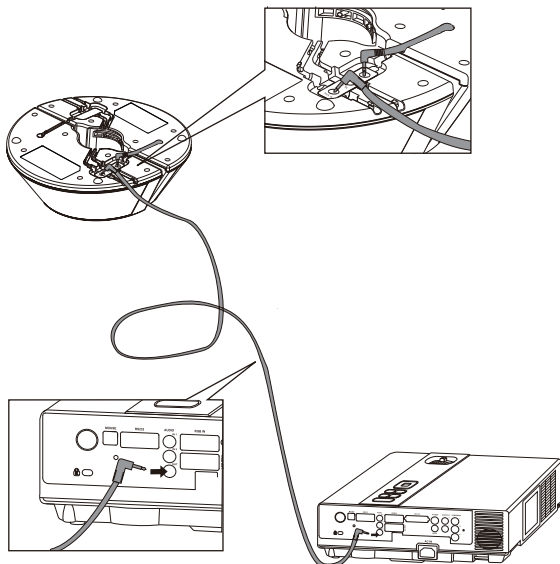

Connecting a power supply

