



# IntelliMix Foundation System

Base Kit for Microsoft Teams Rooms and  
Zoom Rooms

Shure IntelliMix Foundation System (IMXF5) manual, a compute + touch panel kit for Microsoft Teams Rooms and Zoom Rooms. Learn how to install, deploy, and customize

Version: 1.0 (2026-F)

# Table of Contents

<b>IntelliMix Foundation System Base Kit for Microsoft Teams Rooms and Zoom Rooms</b>	<b>3</b>	Install the Compute	18
		Install the Touch Panel	19
		Recommended Display Settings	19
<b>What is the IntelliMix™ Foundation System for Microsoft Teams Rooms and Zoom Rooms?</b>	<b>3</b>	<b>Update IntelliMix Room</b>	<b>19</b>
Related Products	3	<b>IntelliMix DSP</b>	<b>20</b>
<b>Included Hardware and Accessories</b>	<b>3</b>	Acoustic Echo Cancellation (AEC)	20
Model Variations	5	Noise Reduction	21
<b>How to Deploy the IntelliMix Foundation System</b>	<b>6</b>	AI Denoiser	21
System Requirements	6	Deverb	22
Before You Install: Network, Power, and License Requirements	6	Automatic Gain Control (AGC)	22
Step 1: Install and Connect Devices	7	Compressor	23
Step 2: Sign In	8	Delay	23
Step 3: Route Audio and Configure IntelliMix Room DSP	9	Parametric Equalizer	24
Step 4: Make a Test Call	12	<b>Automixer</b>	<b>24</b>
<b>IntelliMix Foundation Compute Parts</b>	<b>12</b>	<b>Matrix Mixer</b>	<b>25</b>
Versions of IntelliMix Room Software	13	Crosspoint Gain	25
<b>IntelliMix Touch Panel Parts</b>	<b>13</b>	Routing Channels	25
Optional Accessories	14	<b>Remote Monitoring and Management with ShureCloud 2</b>	<b>5</b>
How to Share Content on the Displays	14	<b>Troubleshooting</b>	<b>26</b>
<b>Control IntelliMix Room with Designer</b>	<b>15</b>	<b>Additional Resources</b>	<b>26</b>
Find IntelliMix Room in Designer	15	<b>IntelliMix Foundation System Specifications</b>	<b>27</b>
Manage Shure Control and Dante Audio NICs	16	Dimensions	29
<b>Route Audio</b>	<b>16</b>	<b>Important Safety Instructions</b>	<b>31</b>
Use Designer's Auto Route	17	<b>Important Product Regulatory Information</b>	<b>32</b>
<b>Room System Setup Example</b>	<b>18</b>	中国 RoHS	38
<b>Installation Instructions</b>	<b>18</b>	FCC / IC ID	39

---

## IntelliMix Foundation System Base Kit for Microsoft Teams Rooms and Zoom Rooms

---

### What is the IntelliMix™ Foundation System for Microsoft Teams Rooms and Zoom Rooms?

Create, deploy, and manage sophisticated AV solutions for demanding collaboration spaces with this powerful Compute + Touch Panel kit for Microsoft Teams Rooms and Zoom Rooms. Ideal for custom AV system integration, the Windows-based Compute with built-in IntelliMix Room DSP is optimized for use with Shure's extensive portfolio of audio products certified for Microsoft Teams and Zoom Rooms. It provides unparalleled flexibility to deliver pristine audio quality in spaces that require tailored solutions. The high-resolution Touch Panel provides intuitive controls and a convenient content ingest port for effective, people-centric meeting experiences.



This page covers how to deploy the IntelliMix Foundation System with your own devices.

### When to Use the Foundation System vs. a Room Kit

Use the [IntelliMix Foundation System](#) for custom AV room integration with your own cameras, mics, and loudspeakers.

Use an [IntelliMix Room Kit](#) when you need a turnkey solution for small, medium, or large rooms that includes mic, loudspeaker, cameras, and all required accessories.

### Related Products

- To set up an IntelliMix Room Kit, refer to the [IntelliMix Room Kits user guide](#).
- For more details about IntelliMix Room software, refer to the [IntelliMix Room user guide](#).
- Learn more about [Microflex® Ecosystem microphones, loudspeakers](#), and [recommended camera partners](#).

# Included Hardware and Accessories

## Compute

1. IntelliMix Foundation Compute
2. Wall bracket
3. Mounting screws for wall bracket (4 KA3 x 30)
4. Drywall/concrete anchors (4)
5. Power cords and FSP120-ABBN3 power supply for compute (included cords vary by region)
6. 10 ft. (3 m) HDMI cables to connect displays (2)

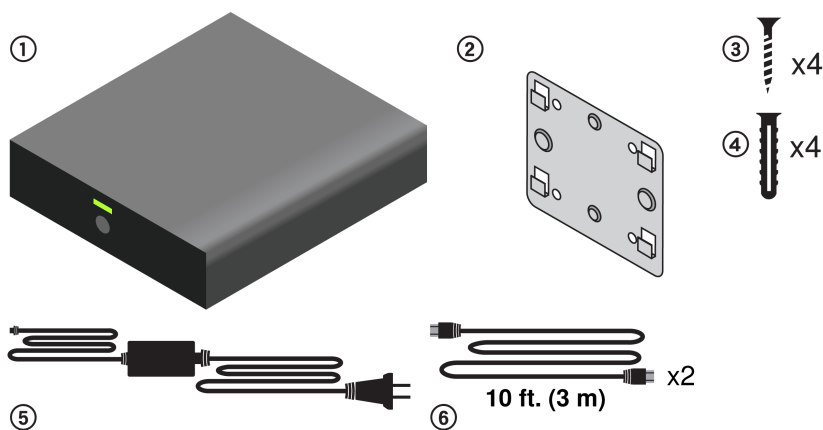

## Touch Panel

1. IntelliMix Touch Panel
2. 6 ft. (1.8 m) USB-C cable for in-room content sharing
3. 25 ft. (7.6 m) Ethernet cable

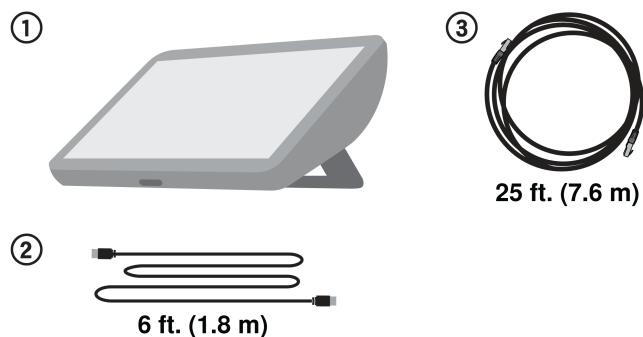

## Cables

1. 25 ft. (7.6 m) Ethernet cable
2. 3 ft. (0.9 m) Ethernet cable
3. 10 ft. (3 m) Ethernet cable
4. 50 ft. (15.2 m) Ethernet cable

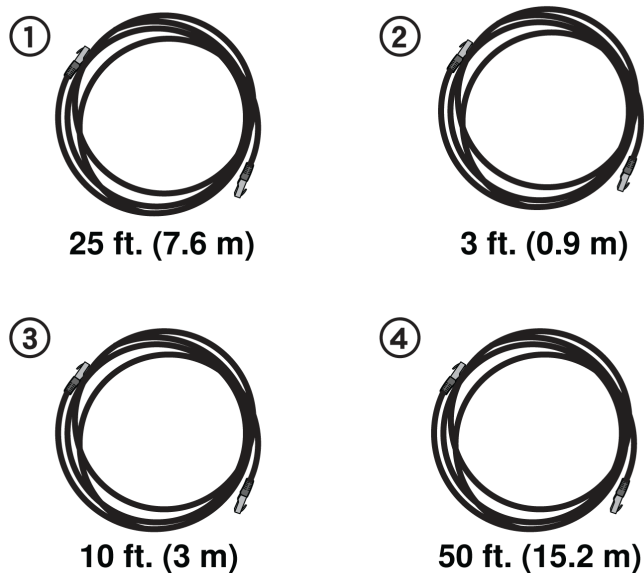

## Network Switch\* and USB-Ethernet Adapter

1. PoE+ network switch\*
2. Network switch power cords and power supply (included cords vary by region)\*
3. USB-to-Ethernet adapter (USB 3.0 to gigabit Ethernet)

\* Not included with IMXF5-NSW or IMXRK-NSW versions.

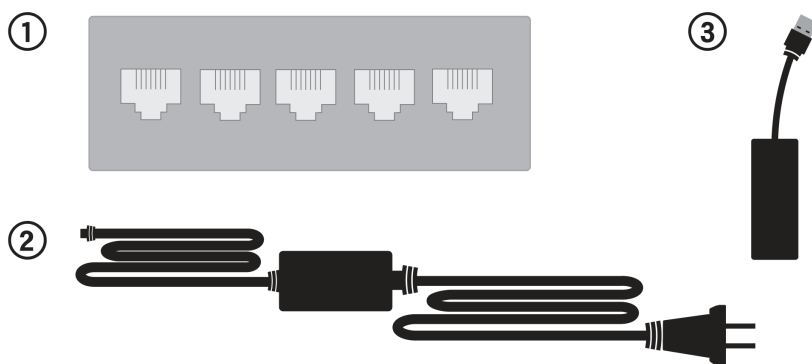

## Model Variations

### IMXF5 Variants

SKU	Description
IMXF5	IntelliMix Foundation System for Microsoft Teams Rooms
IMXF5Z	IntelliMix Foundation System for Zoom Rooms
IMXF5-NSW	IntelliMix Foundation System for Microsoft Teams Rooms, no switch

SKU	Description
IMXF5Z-NSW	IntelliMix Foundation System for Zoom Rooms, no switch

## How to Deploy the IntelliMix Foundation System

These steps show how to integrate the IntelliMix Foundation System into collaboration spaces that use your choice of microphones, loudspeakers, and cameras.

Shure recommends the [Microflex Ecosystem](#) portfolio of networked audio solutions which ensure seamless compatibility and can be precisely tailored to meet your needs for best-in-class collaboration spaces.

Connections and routing will vary depending on room needs and devices used.

After following these steps, you should be able to:

- Connect the compute, touch panel, and PoE+ switch
- Sign in to Microsoft Teams Rooms or Zoom Rooms
- Route audio and adjust IntelliMix Room DSP settings in Shure Designer software

**Note:** See the [IntelliMix Room Kits user guide](#) if you're setting up a kit with MXA902s and Huddly cameras.

## System Requirements

To control IntelliMix Room running on an IntelliMix Foundation Compute, you must meet these requirements:

- **Shure Designer software:** Version 6.5 or newer. Designer should be installed on a separate computer connected to the same network as the compute.
- **IntelliMix Room software:** Version 6.5 or newer. See [Update IntelliMix Room](#) for details about updating.

## Before You Install: Network, Power, and License Requirements

Before you install the IntelliMix Foundation System, IT and AV teams should complete these tasks for a successful deployment.

### Pre-Deployment Checklist for IntelliMix Foundation System

Task	Requirements
<b>Purchase Microsoft Teams Rooms or Zoom Rooms licenses for each room</b>	Account credentials are required to sign in.  For more information, see:  <a href="#">Microsoft Teams Rooms licensing overview</a> <a href="#">Zoom Rooms license types</a>
<b>Prepare your network</b>	Review required ports, protocols, and firewall changes for Microsoft Teams Rooms or Zoom Rooms and IntelliMix Room.  <a href="#">Get your network ready for Microsoft Teams</a> <a href="#">Firewall configuration for Zoom Rooms</a> <a href="#">Required firewall changes for IntelliMix Room software</a>

Task	Requirements
<p><b>Plan for cable runs and power for each room</b></p>	<p>These vary depending on your room and devices. See <a href="#">Room System Setup Examples</a> to get ideas for possible device combinations.</p> <p>Shure recommends shielded Cat6 cables. See <a href="#">Specifications</a> for more details.</p>
<p><b>Plan out where to install microphones, loudspeakers, cameras, and other peripherals</b></p>	<p>Before deployment, plan where you will install all devices so that all talkers in the room can be heard and seen.</p> <p>The <a href="#">Microflex Ecosystem</a> portfolio of networked audio solutions ensures seamless compatibility and can be precisely tailored to meet your needs for best-in-class collaboration spaces.</p>

Additional Microsoft Teams Rooms resources:

- [Overview of planning, deploying, and managing Microsoft Teams Rooms](#)
- [Prepare your environment for Teams Rooms](#)
- [Microsoft Teams Rooms on Windows device security](#)

Additional Zoom Rooms resources:

- [Getting started with Zoom Rooms](#)
- [Getting started with Zoom Device Management](#)

## Step 1: Install and Connect Devices

1. Install all devices in the room. Installation instructions:
  - [Compute installation](#)
  - [Touch panel installation](#)
2. Connect the compute and PoE+ switch to power using the provided power supplies and cords.

Connect any microphones, loudspeakers, or cameras that require PoE or PoE+ to the PoE+ switch.

**-NSW versions:** Use a managed gigabit switch that provides PoE+. Turn off any energy-efficient Ethernet (EEE) or IGMP features on the switch.

3. Make these connections:
  - **1:** Compute USB port to PoE+ switch using provided USB-Ethernet adapter and Ethernet cable
  - **2:** Compute touch console port to touch panel using provided Ethernet cable
  - **3:** Compute LAN port to enterprise network with internet access. An internet connection is required to run Microsoft Teams Rooms or Zoom Rooms.

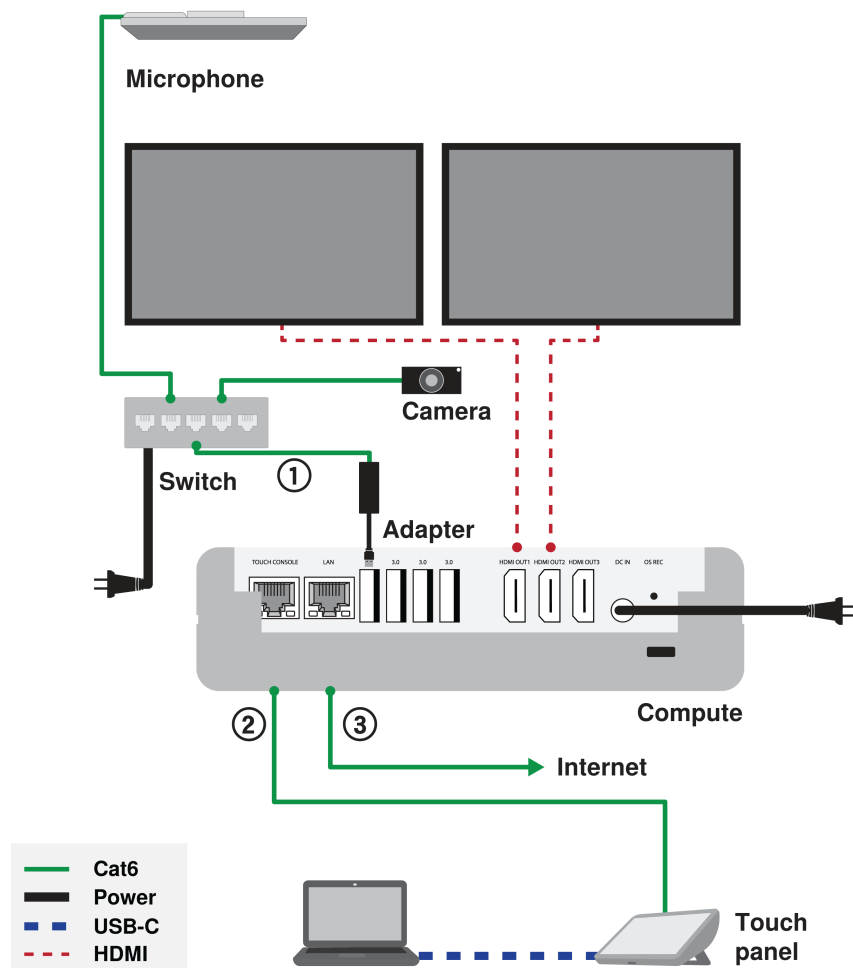

IntelliMix Foundation System connections with example devices

**Note:** If you aren't using a link-local setup as shown, you may need to adjust the control network. See [Manage Shure Control and Dante Audio NICs](#) for details.

- Press the power button to turn on the compute. Windows may reboot to install updates before prompting you to sign in.

**Note:** Windows updates can take time. Do not turn off the compute during an update.

For room system setup examples, visit [shure.com/imxf5](https://shure.com/imxf5).

## Step 2: Sign In

You can connect a keyboard and mouse to the IntelliMix Foundation Compute, if desired.

- **Sign in**
  - Use the touch panel to enter your credentials.
  - You can also use Autopilot and Autologin for Microsoft Teams Rooms. See [Microsoft's instructions](#) for details.
- **Select devices.** Select the correct microphone, speaker, and camera sources using the touch panel.
  - Microphone: IntelliMix Room Echo Cancelling Speakerphone
  - Speaker: IntelliMix Room Echo Cancelling Speakerphone

**Note:** Do not choose the Shure IMXTP11 touch panel for the mic, speaker, or camera device in Zoom Rooms.

## How to Switch Windows Accounts

The IntelliMix Foundation Compute has 2 built-in Windows accounts.

You may need to sign in to the administrator account for more advanced system configuration or troubleshooting.

## Microsoft Teams Rooms

- **Skype for Business (Microsoft Teams Rooms) account:**
  - Default account when the system starts
  - Runs Microsoft Teams Rooms
- **Administrator account:**
  - Can make any change to the system with password (default: sfb)
  - Not used during meetings

### To switch accounts:

1. Using the touch panel, go to More > Settings and enter the password (default: sfb).
2. Select Windows Settings and enter the password (default: sfb).

## Zoom Rooms

Connect a keyboard and mouse to the compute to switch Windows accounts.

- **Zoom Rooms account:**
  - Default account when the system starts
  - Runs Zoom Rooms
- **Zoom Rooms administrator account:**
  - Can make any change to the system with password (default: shure100)
  - Not used during meetings

### To switch accounts:

1. Using the touch panel, go to Settings (gear icon) > General > Windows settings .
2. Enter the Room passcode you received from Zoom.
3. Select the ZoomRoomsAdmin account and enter the password (default: shure100).

## Step 3: Route Audio and Configure IntelliMix Room DSP

To make changes to IntelliMix Room audio settings, you'll need to [install Designer](#) on a separate computer. Designer lets you control and route audio between many Shure devices in one place.

**Important:** Check that Designer and IntelliMix Room are using version 6.5 or newer.

## Route Audio

Use Designer or Dante Controller to route audio. Routing varies depending on room needs and devices used.

- **Designer:** Routes networked audio to other Shure devices. Good for rooms with [Microflex Ecosystem devices](#).
- **Dante Controller:** Routes networked audio to any other Dante device. Good for rooms with devices from a mix of manufacturers.

To route using Designer:

1. Connect the computer with Designer to the PoE+ switch.

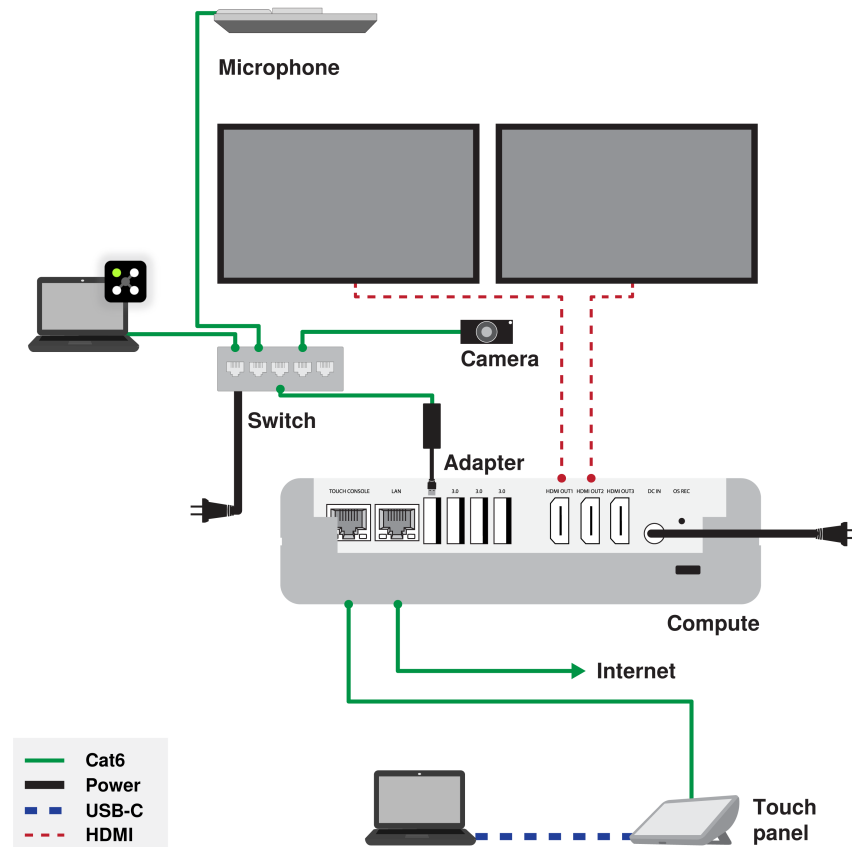

### Separate computer with Designer added to route audio and control IntelliMix Room

2. Open Designer. Check that you're connected to the correct network in File > Designer preferences. You should see the compute in the Online devices list.
3. From Designer's home screen, select File > New online room to make a new online room.
4. Expand the Devices panel to see all online devices. Drag the compute and any other Shure devices you want to route to into the room.

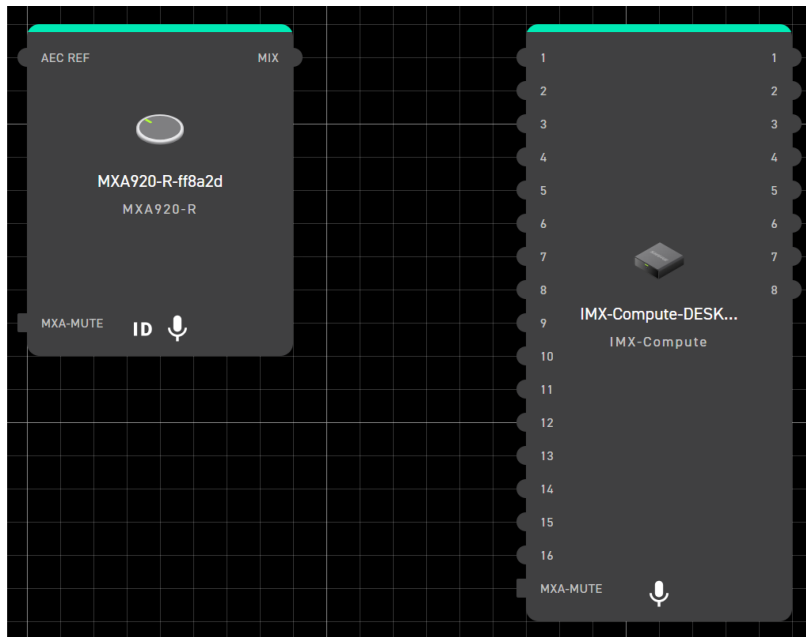

**MXA920 and IntelliMix Foundation Compute in an online room**

5. Select Auto route. Designer then routes audio and applies settings that are optimized for your combination of devices. You can also change routes or create new ones after auto routing the room. Adjust to fit your devices and space.

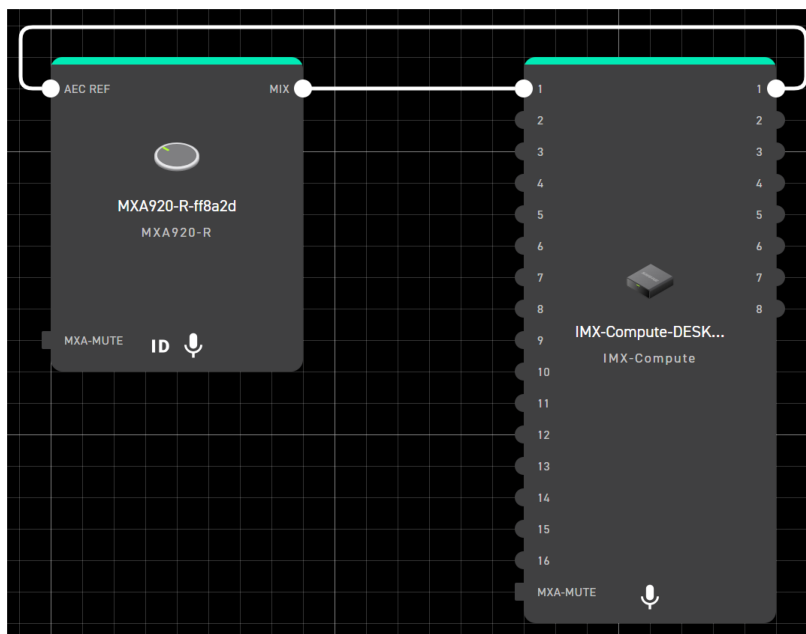

**MXA920 and IntelliMix Foundation Compute after auto route**

## Configure IntelliMix Room Settings

From the room's Routing view in Designer, double-click the compute to open the device view. You can adjust DSP settings, change matrix mixer routes, adjust levels, and more.



Device view for an IntelliMix Foundation Compute

- Learn more about [IntelliMix DSP blocks](#)
- Learn more about IntelliMix Room's [matrix mixer](#), which offers the flexibility to route any input to any output
- [IntelliMix Room user guide](#)

## Step 4: Make a Test Call

Check that **IntelliMix Room Echo Cancelling Speakerphone** is set as the speaker and microphone source. Select the correct camera source.

Make a test call and have someone on the other end tell you how your signal sounds. Use Designer to adjust Shure audio devices as needed.

Your system is set up and ready to use after completing these steps.

## IntelliMix Foundation Compute Parts

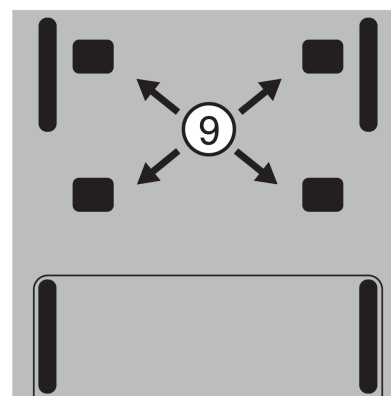
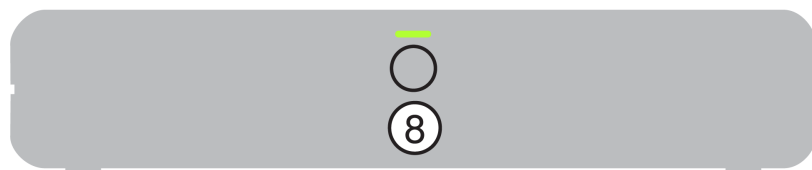
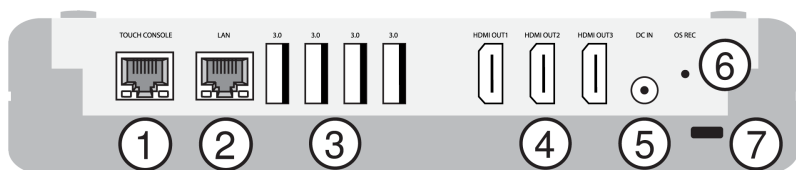

1. RJ45 for connection to IntelliMix Touch Panel
2. RJ45 for connection to internet

3. USB-A 3.0 (x4)
4. HDMI out (x3)
5. DC IN: Power
6. OS REC: Not enabled
7. Kensington lock slot
8. Power button
9. Mounting holes for wall bracket

## Versions of IntelliMix Room Software

There are 2 separate versions of IntelliMix Room that serve different purposes:

- IntelliMix Room software for [IntelliMix Room Kits](#) and [IntelliMix Foundation System](#)
- [IntelliMix Room software DSP](#) for third-party compute devices

**Note:** Do not try to install the [IntelliMix Room software DSP](#) on the compute included with the IntelliMix Foundation System.

### IntelliMix Room Software Comparison

	IMX Room for Room Kits/Foundation System	IMX Room for Third-Party Devices
<b>Comes installed on device</b>	X	
<b>Customer installs on device</b>		X
<b>Updated through Windows update process</b>	X	
<b>Updated by customer</b>		X

## IntelliMix Touch Panel Parts

The touch panel functions as a display to control the IntelliMix Foundation Compute. Installers or administrators can use the touch panel to control Windows and Microsoft Teams Rooms or Zoom Rooms settings.

Meeting participants can use the touch panel to join and start meetings. Touch the screen to wake the system.

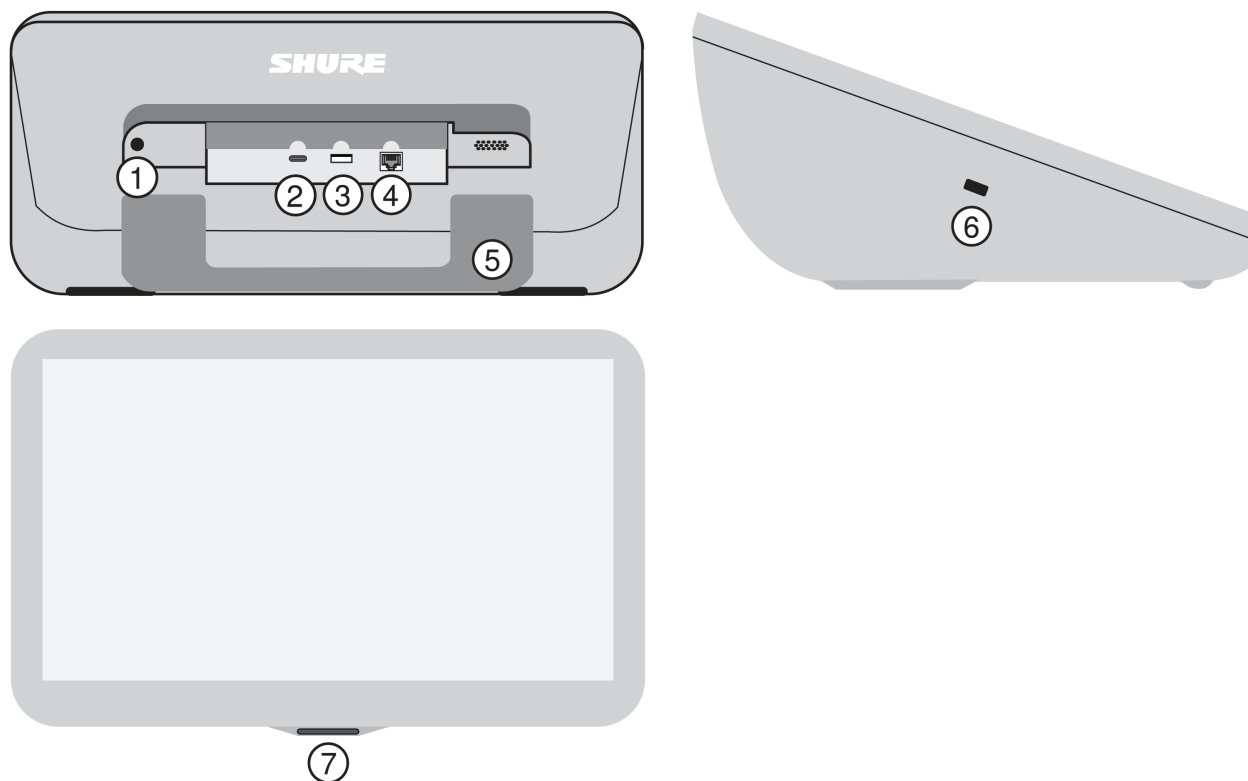

1. 3.5 mm headphone jack
2. USB-C ingest for content sharing
3. USB-A
4. RJ45 for connection to IntelliMix Foundation Compute
5. Movable kickstand
6. Kensington lock slot
7. Passive infrared sensor: The screen automatically turns on when a person is detected. The sensor works best when the kickstand is down.

*Not supported in Zoom Rooms.*

## Optional Accessories

- [A-IMXTP11-WB wall bracket for touch panel](#)

## How to Share Content on the Displays

You can share content on the displays connected to an IntelliMix Foundation Compute. To share content, use the included USB-C cable to connect a laptop to the touch panel's USB-C port.

You can share content in calls or locally in the room outside of calls.

Zoom Rooms: In Zoom Device Management, turn on the setting that allows HDMI content share locally before and during the meetings.

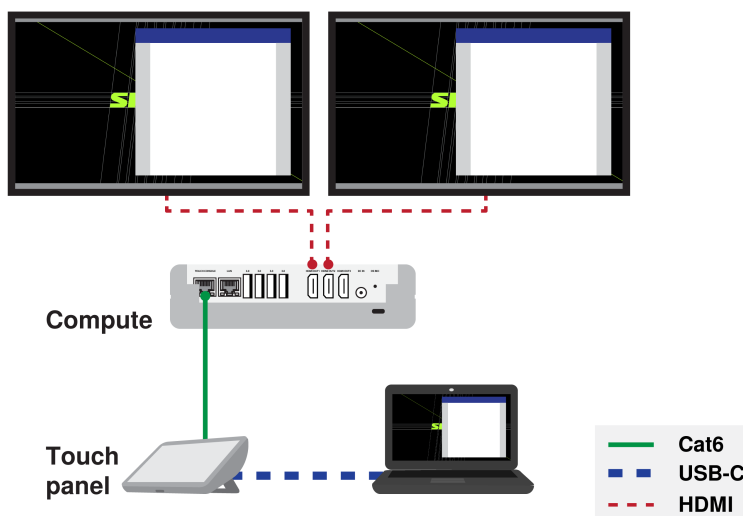

## Control IntelliMix Room with Designer

For full control of all IntelliMix Room settings, [download Designer software](#) on a separate computer connected to the same network as the device with IntelliMix Room. Designer offers routing and control for Shure devices.

In Designer, each installation of IntelliMix Room on your network appears as a separate device.

### Ways to Control IntelliMix Room

IntelliMix Room platform	Designer required?	Notes
<a href="#">IntelliMix Foundation System with your own AV peripherals</a>	Yes	Designer is required to control IntelliMix Room settings.
<a href="#">IntelliMix Room Kits</a>	No	Room kits feature zero-touch provisioning, and Designer is not required to set up a room.
<a href="#">IntelliMix Room running on supported system</a>	No	Optional, but not required. You can use the <a href="#">room setup feature</a> to discover, route, and configure a room with other Shure devices.  Use Designer for full control of all IntelliMix Room settings.

## Find IntelliMix Room in Designer





**IntelliMix Foundation Compute:** Each compute appears as a separate device.

**IntelliMix Room on third-party device:** Each installation of IntelliMix Room appears as a separate device. Each installation's name matches the computer's network name.

Online devices

Search View: Devices Add by IP IP group: None Hide offline devices: Off

Drag column headers here to set row groups

Name	Status	Model	Room	IP address...	Firmware
 IMX-Compute-DESKTOP-2RB37RU		IMX-Compute	Untitled room-1	169	6.5.0.51
 MXA920-R-ff8a2d	ID	MXA920-R	Untitled room-1	169	6.4.61.0
 IMX-RM-PCNIPILC		IMX-Room	5-S-conf	169	6.1.0.33

IntelliMix Foundation Compute and IntelliMix Room installation in online devices list

To find any online installations, go to Online devices.

**If you can't find some installations:**

1. Go to the computer that won't appear in Designer.
2. Click the IntelliMix Room icon in the system tray.
3. Make sure IntelliMix Room is using the same Shure control NIC as Designer.

## Manage Shure Control and Dante Audio NICs

IntelliMix Room sends 2 types of data over the network: Shure control data and Dante audio data.

**Shure control NIC:**

- Choose the network that Designer uses.
- Used for device discovery and control

**Dante audio NIC:**

- Choose the same network as other Dante devices to send audio between devices.
- Cannot use Wi-Fi
- Used to carry Dante digital audio

When installing IntelliMix Room on a third-party device, you will be asked to choose a network for each one. You can use the same NIC for Shure control and Dante audio, or use 2 different NICs to separate the traffic.

**To change NIC settings later:** Click the IntelliMix Room icon in the system tray and go to Network. On an IntelliMix Foundation Compute, [switch to the administrator account](#) to see the system tray.

To change Designer's NIC, go to Designer preferences.

## Route Audio

To route audio to or from the IntelliMix Foundation Compute, use Designer or Dante Controller:

**Option 1: Use Designer**

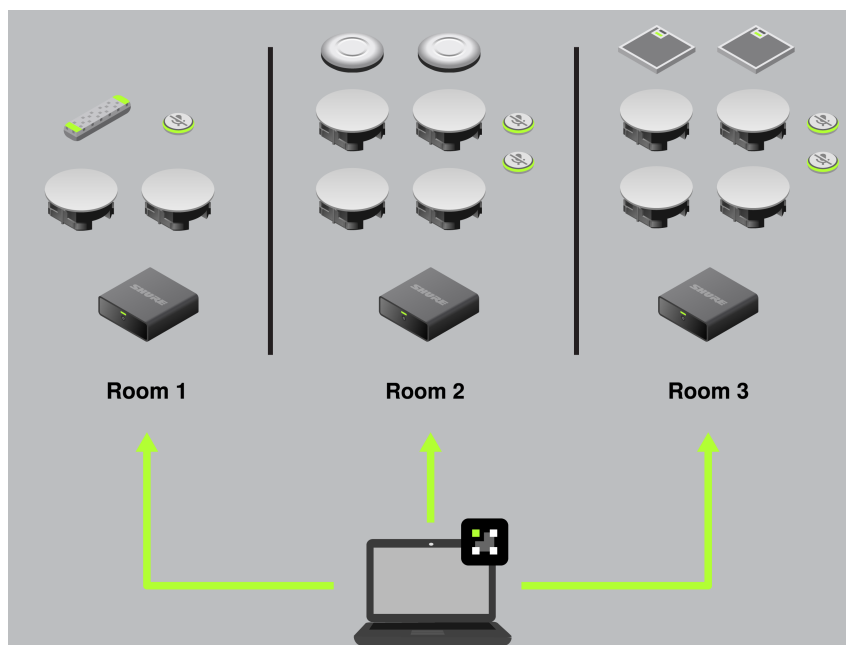

- Auto route feature creates audio and mute control routes between Shure devices
- Auto route sets up devices with Shure's recommended settings
- Full access to Shure device settings
- Create and manage many rooms with Shure devices

You can also use Designer to create your own audio routes between Shure devices outside of the auto route feature.

#### Option 2: Route audio with Dante Controller

- Create audio routes to any Dante device
- Use Designer to access all Shure device settings

## Use Designer's Auto Route

Designer's auto route speeds up the process of connecting systems with 1 audio processor and at least 1 microphone. Auto route also creates mute control routes in rooms with MXA network mute buttons. When you select Auto route, you can direct Designer to:

- Create audio routes and mute control routes
- Adjust audio settings
- Turn on mute synchronization
- Enable LED logic control for applicable devices

The settings are optimized for your particular combination of devices. You can adjust settings further, but auto route gives you a good starting point. Auto route works with any device in Designer.

#### To use auto route:

1. Place all relevant devices in a design.
2. Select Auto route. Designer optimizes microphone and DSP settings for your equipment combination.

If you remove or add devices, select Auto route again.

**Note:** The auto route process clears any manual routes you may have made in your design.



If wall mounting, use the included mounting bracket:

1. Use the included screws to attach the bracket to the wall with the mounting hooks facing up. If you're not installing on a stud, use the included anchors.
2. The compute slides onto the wall bracket. When installed, the cables come out the top end of the compute. It's easiest to make all required connections to the compute, attach the cable cover, and then slide it on to the wall bracket.

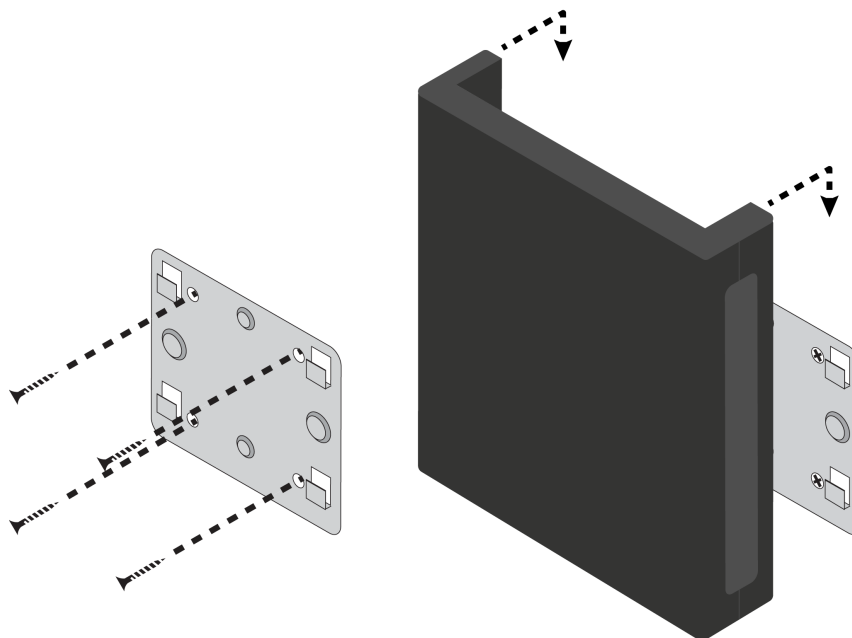

## Install the Touch Panel

Place on a table or install on a wall using the optional [A-IMXTP11-WB wall bracket](#) (sold separately).

**Note:** The PIR sensor doesn't work when mounted on a wall.

## Recommended Display Settings

For best results, use these settings for front-of-room displays connected to an IntelliMix Foundation Compute:

- Turn off any automatic power-off or automatic standby features.
- Turn off the display's eco settings.

These settings ensure that front-of-room displays turn on when Microsoft Teams Rooms or Zoom Rooms wakes. Consult your display manufacturer's documentation or these sources for more guidance:

- [Microsoft Teams Rooms documentation](#)
- [Zoom Rooms documentation](#)

## Update IntelliMix Room

Check your current version in Designer, ShureCloud, or by clicking the IntelliMix Room icon in the system tray.

To update, follow the steps that match your system:

## IntelliMix Foundation Compute

IntelliMix Room is automatically updated during nightly Windows maintenance when a new version is available.

To update manually:

1. Turn on the compute and make sure it has an internet connection. The software automatically checks for updates within 15 minutes of booting up.
2. Use the touch panel to sign in to the administrator account.
3. Go to `C:\Program Files\Shure\downloads` and look for the IntelliMix Room .exe file with the new version. If there is no newer version, the folder will be empty.
4. Run the .exe file to launch the installer. The software installs the new version and will prompt you to restart the compute to finish the update.

## Third-Party Device Running IntelliMix Room

Right-click the IntelliMix Room icon in the system tray and select Check for updates.

---

## IntelliMix DSP

IntelliMix Room software uses DSP to clean up common meeting room audio problems. Open an IntelliMix Room installation in Designer to see all DSP settings.

For full details about DSP settings, see the [IntelliMix Room user guide](#).

Here's what some of the DSP blocks can do for your signal:

## Acoustic Echo Cancellation (AEC)

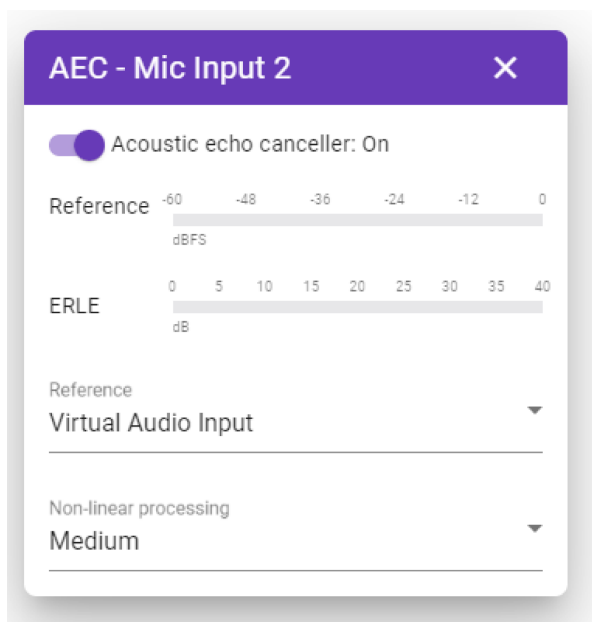

AEC keeps your mic signal clear and free of distracting echo from the far end. IntelliMix Room uses per-channel AEC, which means that each input channel can have its own reference signal. You can even set up stereo left and right references in rooms with stereo audio.

## Noise Reduction

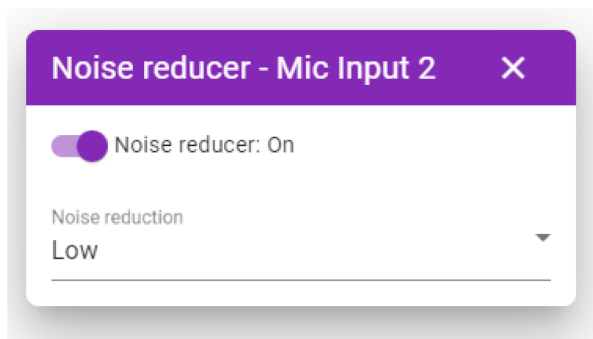

This DSP feature keeps the focus on your voice by reducing the level of background noise. Noise reduction is perfect for constant noise sources like:

- Loud HVAC systems
- Network switch or server fans
- Display projectors

Noise reduction and the AI denoiser work together seamlessly to control constant background noise and fast-occurring noises in your audio signal.

## AI Denoiser

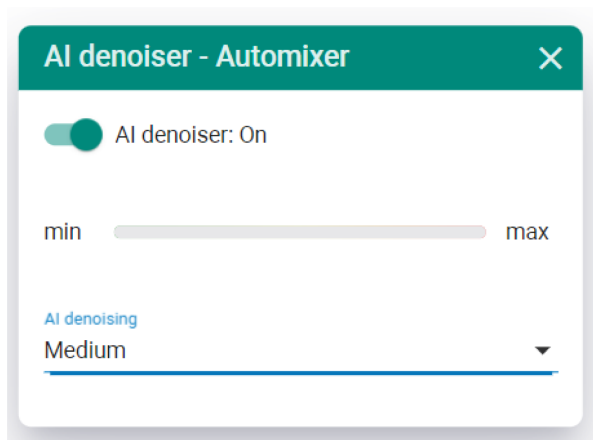

Stop random, fast-occurring noises from cluttering up your audio signal with the AI denoiser. This DSP block minimizes sounds such as:

- Typing
- Shuffling papers
- Slamming doors

Let the AI denoiser take care of random bursts of noise and then use noise reduction to control constant background noise (such as HVAC systems or traffic).

# Deverb

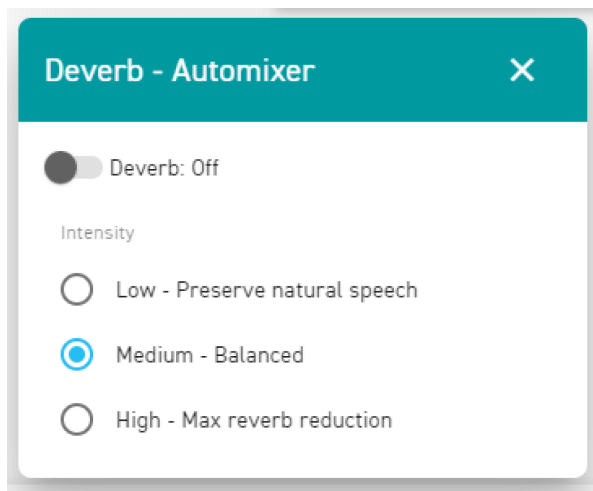

Deverb helps improve the signal going to the far end by reducing the amount of reverb. Use deverb in rooms that:

- Have lots of hard, reflective surfaces
- Don't have proper acoustic treatment

To turn on deverb, open IntelliMix Room in Designer and go to Schematic > Deverb. Deverb is available on the automix output signal.

Choose from 3 intensity options: low, medium, or high.

For best results, make a test call with your videoconferencing software and have someone on the other end tell you how your signal sounds as you test each deverb setting.

## Automatic Gain Control (AGC)

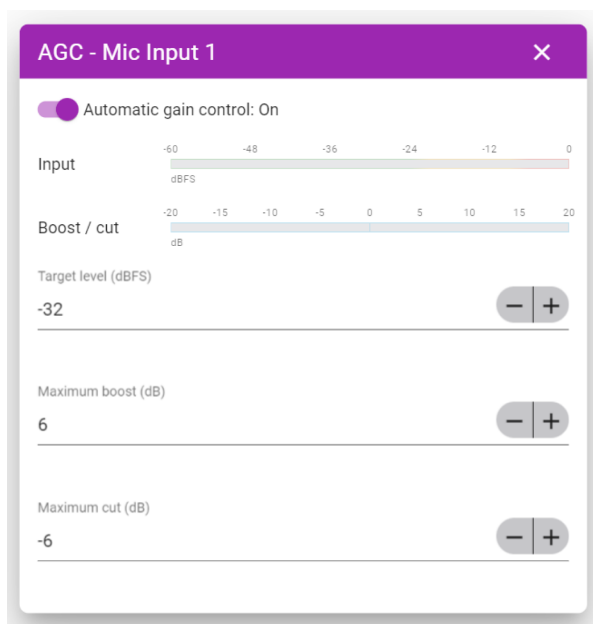

Automatic gain control adjusts channel levels to create a consistent volume for all talkers in all scenarios. For quieter voices, it increases gain. For louder voices, it attenuates the signal.

AGC is post-fader and adjusts the channel level after the input level has been set. Use AGC when:

- The distance between the talkers and the microphone varies
- Many different people will use a room's conferencing system

## Compressor

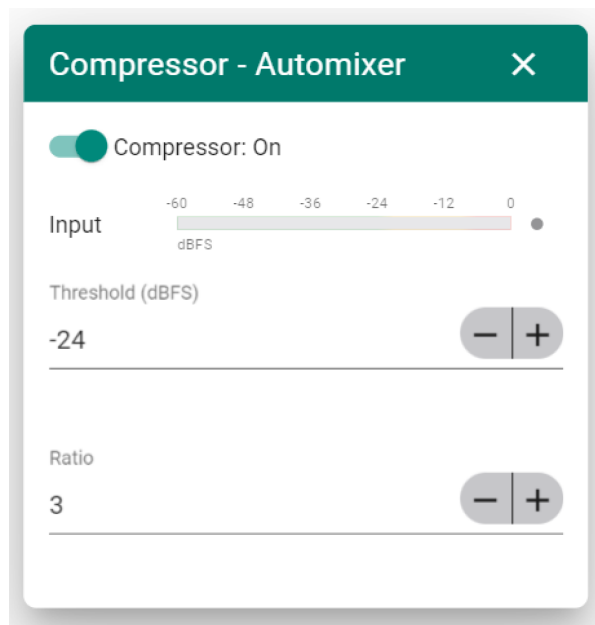

Use the compressor to control the dynamic range of a signal. This means that if there's an unexpected spike in a signal's level, the compressor reduces the signal level to be closer to typical levels.

IntelliMix Room has compressors for:

- Your microphone signal from the automixer
- All far-end signals going to Dante outputs, PC outputs, or the virtual audio output

## Delay

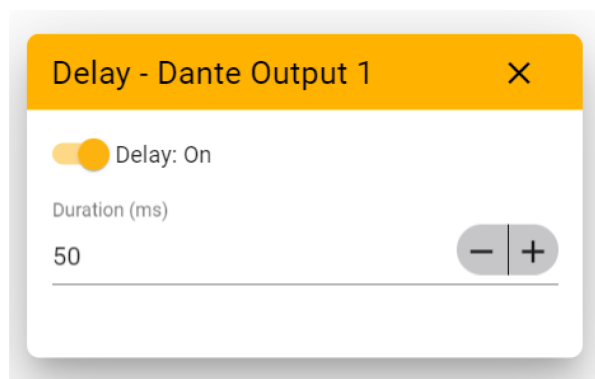

Delay is useful for synchronizing audio and video signals or time-aligning loudspeakers in different locations for even coverage.

This block is available on any of the Dante output signals. Adjust the delay in milliseconds and test accordingly.

## Parametric Equalizer

Improve audio quality by adjusting a signal's frequency response with the parametric equalizer. PEQ is available on inputs and outputs.

### Uses for EQ

EQ Application	Suggested Settings
<b>Treble boost for improved speech intelligibility</b>	Add a high shelf filter to boost frequencies greater than 1 kHz by 3-6 dB
<b>HVAC noise reduction</b>	Add a low-cut filter to attenuate frequencies below 200 Hz
<b>Reduce flutter echoes and sibilance</b>	Identify the specific frequency range that "excites" the room: <ol style="list-style-type: none"> <li>1. Set a narrow Q value.</li> <li>2. Increase the gain to between +10 and +15 dB, and then experiment with frequencies between 1 kHz and 6 kHz to pinpoint the range of flutter echoes or sibilance.</li> <li>3. Reduce the gain at the identified frequency (start between -3 and -6 dB) to minimize the unwanted room sound.</li> </ol>
<b>Reduce hollow, resonant room sound</b>	Identify the specific frequency range that "excites" the room: <ol style="list-style-type: none"> <li>1. Set a narrow Q value.</li> <li>2. Increase the gain to between +10 and +15 dB, and then experiment with frequencies between 300 Hz and 900 Hz to pinpoint the resonant frequency.</li> <li>3. Reduce the gain at the identified frequency (start between -3 and -6 dB) to minimize the unwanted room sound.</li> </ol>



# Automixer

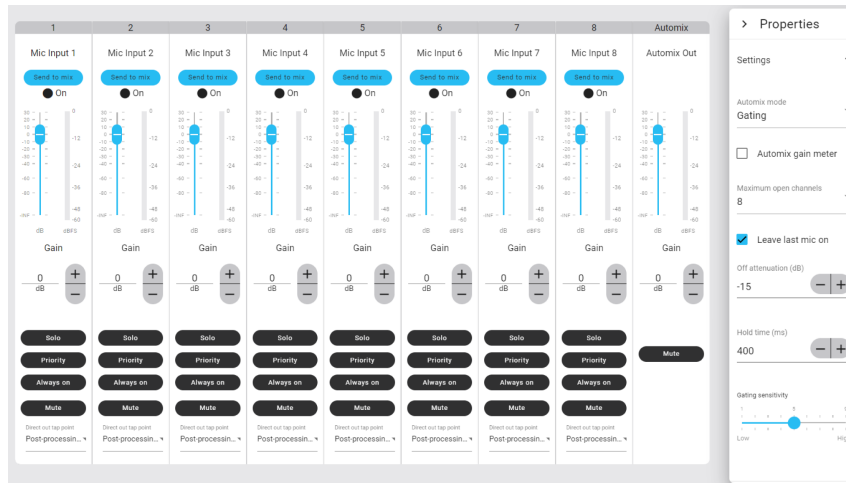

The automixer mixes all mic input channels into a convenient single output for your videoconferencing software. Shure's automixer algorithms are known for fast-acting, seamless channel gating. This means everyone's voice is picked up clearly without having too many channels open at the same time.

For best results, pair IntelliMix Room with Shure microphones in the room for easy deployment.

## Matrix Mixer

The matrix mixer routes audio signals between inputs and outputs for simple and flexible routing:

- Send a single input channel to multiple outputs
- Send multiple input channels to a single output

## Crosspoint Gain

Crosspoint gain adjusts the gain between a specific input and output, to create separate submixes without changing input or output fader settings. Select the dB value at any crosspoint to open the gain adjustment panel.

**Gain staging:** Input fader > crosspoint gain > output fader

## Routing Channels

Connect inputs and outputs by selecting the box where they intersect.

# Remote Monitoring and Management with ShureCloud

Use [ShureCloud](#) to remotely view information about IntelliMix Foundation System devices.

To add an IntelliMix Foundation System to ShureCloud, you only need to add the IntelliMix Foundation Compute. Use one of the following methods to add the compute:

- Scan the local network for devices, or
- Use the MAC address printed on the bottom of the compute

Adding the compute also adds the touch panel and any other Shure devices in the same Designer room as the compute. After the compute is added to ShureCloud, it presents those other devices to ShureCloud. This group of devices displays as nested under the compute in the Connections view.

See the ShureCloud user guide for detailed instructions about [how to add devices to your ShureCloud account](#).

# Troubleshooting

## IntelliMix Foundation System Troubleshooting

Problem	Solution
<b>Can't hear far-end talker and they can't hear me</b>	<p>Check that Microsoft Teams or Zoom Rooms is using the correct devices:</p> <p><b>Microphone:</b> IntelliMix Room Echo Cancelling Speaker-phone</p> <p><b>Speaker:</b> IntelliMix Room Echo Cancelling Speakerphone</p> <p>Do not choose the Shure IMXTP11 touch panel for the mic, speaker, or camera device.</p>
<b>Can't see IntelliMix Foundation Compute in Designer or Dante Controller</b>	<p>First, check that IntelliMix Room and Designer are running version 6.5 or newer (see <a href="#">System Requirements</a>). Older versions of Designer have limited support for the IntelliMix Foundation System.</p> <p>Check that the computer running Designer or Dante Controller is connected to the included PoE+ switch.</p> <p>In Designer, check that you're using the correct network in <b>File &gt; Designer preferences</b>.</p>
<b>Can't discover networked Shure microphones or loudspeakers in Designer that are on the enterprise network</b>	<p>To route to these devices in Designer, connect them to the included PoE+ switch (the same one that the IntelliMix Foundation Compute is connected to). Then check that you're using the correct network in <b>File &gt; Designer preferences</b>.</p>
<b>Display doesn't turn on when the touch panel wakes the system</b>	<p>Check and adjust your display's settings. See the <a href="#">Recommended Display Settings</a> for more information.</p>
<b><a href="#">Auto setup feature</a> doesn't work with MXA310, MXA710, MXA901, or MXA920</b>	<p>Auto setup is only for IntelliMix Room Kits with MXA902s.</p> <p>The feature doesn't work with installations of the IntelliMix Foundation System and other microphones, loudspeakers, and cameras.</p>

# Additional Resources

- [Shure Knowledge Base FAQs](#)
- [Command strings for Shure devices](#)
- [IP Ports and Protocols for Shure Devices](#)
- [Firewall Rules for Shure Software Applications](#)
- [Shure API documentation](#)
- [Shure Enterprise Networking Troubleshooting Checklist](#)
- [Training from Shure Academy](#)
- [Shure Collaboration & Conferencing YouTube channel](#)

## Download Shure Software

- [Shure Designer](#)
- [ShureCloud](#)
- [Shure Update Utility](#)
- [Shure Discovery](#)
- [Software and firmware archive](#)

---

# IntelliMix Foundation System Specifications

## General

### Operating Temperature Range

0°C (32°F) to 40°C (104°F)

### Storage Temperature Range

-20°C (-4°F) to 60°C (140°F)

## IntelliMix Foundation Compute

### CPU

12th generation Intel Core i5 processor

### Memory

16 GB DDR4

### Storage

256 GB

### Graphics

Intel UHD Graphics for 12th generation Intel processors

### Operating System

Windows 11 IoT Enterprise

## Software

Microsoft Teams Rooms or Zoom Rooms and IntelliMix Room (8-channel)

## Inputs and Outputs

<b>RJ45 (LAN)</b>	1
<b>RJ45 (To touch console)</b>	1
<b>USB-A 3.0</b>	4
<b>HDMI out</b>	3
<b>Power (DC IN)</b>	1

## Bluetooth Frequency Range

2402 MHz to 2480 MHz

## Bluetooth Output Power

<b>Bluetooth</b>	20 dBm EIRP maximum
<b>BLE</b>	10 dBm EIRP maximum

## WLAN Frequency Bands

2.4 GHz and 5 GHz

## WLAN Output Power

Country-dependent

## Antenna Type

Integral

## Power Supply

FSP120-ABBN3

## Power Consumption

120 W maximum

## IntelliMix Touch Panel

### Resolution

1920 x 1080

### Frequency Refresh Rate

60 Hz

## Touch System

<b>Type</b>	Capacitive touch
<b>Surface Treatment</b>	Anti-fingerprint, anti-glare

## Motion Sensor

PIR sensor for automatic wake-up

## Inputs and Outputs

<b>Audio out (3.5 mm)</b>	1
<b>USB-C (Content sharing)</b>	1
<b>USB-A 2.0</b>	1
<b>RJ45 (To compute)</b>	1

## Input Power

*Delivered by DisplayLink over Cat6*

52V DC (0.49 A)

## Power Consumption

13 W maximum

## Cable Requirements for Compute to Touch Panel

Cat6, shielded cable recommended

## Maximum Cable Length for Compute to Touch Panel

<b>Shielded Cable</b>	200 ft. (60.9 m)
<b>Unshielded Cable</b>	30 ft. (9 m)

## Dimensions

### IntelliMix Foundation Compute

- A: 1.6 in. (40.17 mm)
- B: 7.7 in. (196 mm)
- C: 7.7 in. (196 mm)

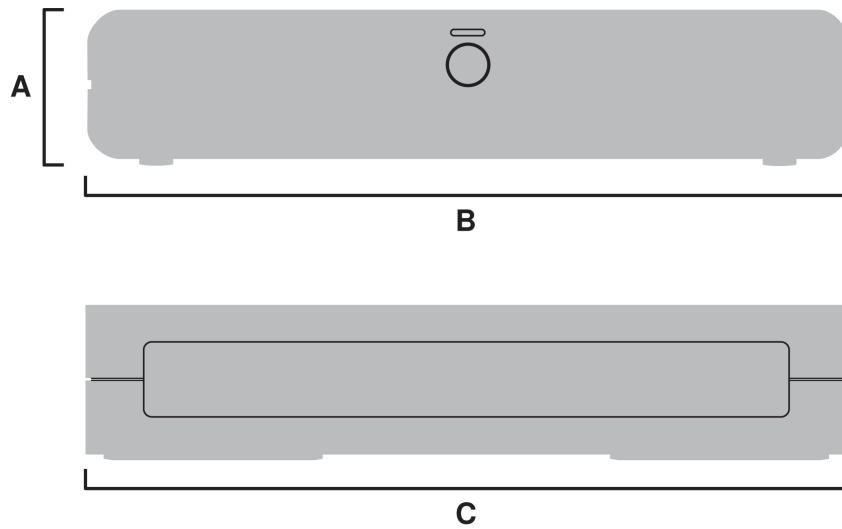

**Weight:** 2.4 lb. (1.1 kg)

## IntelliMix Touch Panel

- A: 3.2 in. (82.33 mm)
- B: 6.7 in. (169.63 mm)
- C: 0.8 in. (21.21 mm)
- D: 7.2 in. (183.25 mm)
- E: 11.2 in. (284.51 mm)

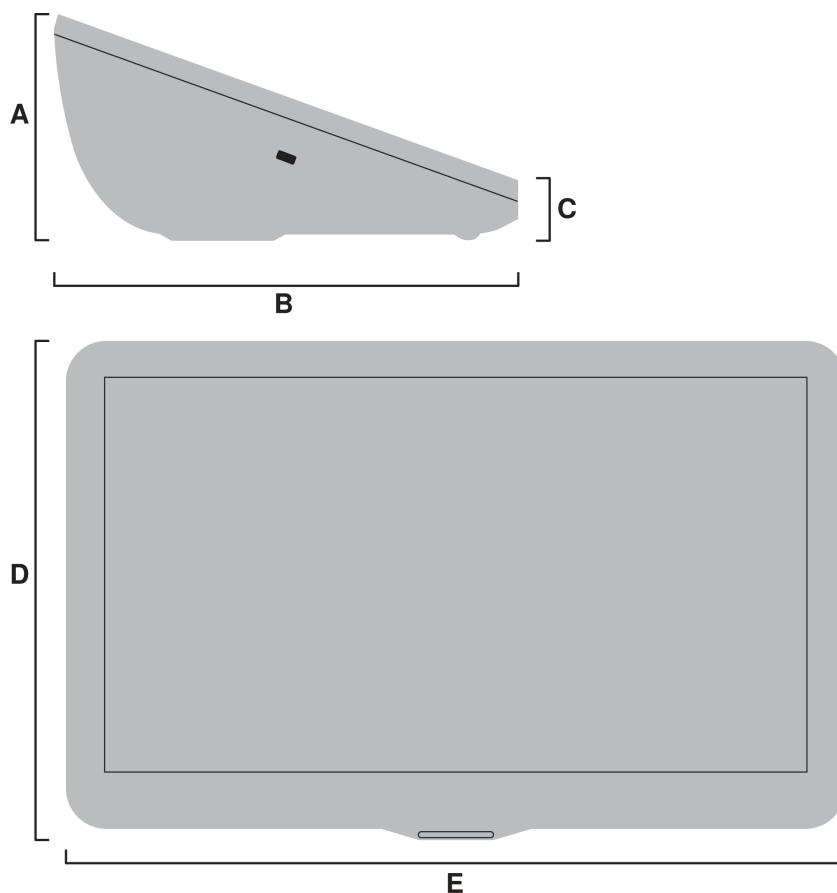

**Weight:** 2.8 lb. (1.3 kg)

## Important Safety Instructions

⚠	This symbol indicates that dangerous voltage constituting a risk of electric shock is present within this unit.
⚠	This symbol indicates that there are important operating and maintenance instructions in the literature accompanying this unit.

1. READ these instructions.
2. KEEP these instructions.
3. HEED all warnings.
4. FOLLOW all instructions.
5. DO NOT use this apparatus near water.
6. CLEAN ONLY with dry cloth.
7. DO NOT block any ventilation openings. Allow sufficient distances for adequate ventilation and install in accordance with the manufacturer's instructions.
8. DO NOT install near any heat sources such as open flames, radiators, heat registers, stoves, or other apparatus (including amplifiers) that produce heat. Do not place any open flame sources on the product.
9. DO NOT defeat the safety purpose of the polarized or grounding type plug. A polarized plug has two blades with one wider than the other. A grounding type plug has two blades and a third grounding prong. The wider blade or the third

prong are provided for your safety. If the provided plug does not fit into your outlet, consult an electrician for replacement of the obsolete outlet.

10. PROTECT the power cord from being walked on or pinched, particularly at plugs, convenience receptacles, and the point where they exit from the apparatus.
11. ONLY USE attachments/accessories specified by the manufacturer.
12. USE only with a cart, stand, tripod, bracket, or table specified by the manufacturer, or sold with the apparatus. When a cart is used, use caution when moving the cart/apparatus combination to avoid injury from tip-over.



13. UNPLUG this apparatus during lightning storms or when unused for long periods of time.
14. REFER all servicing to qualified service personnel. Servicing is required when the apparatus has been damaged in any way, such as power supply cord or plug is damaged, liquid has been spilled or objects have fallen into the apparatus, the apparatus has been exposed to rain or moisture, does not operate normally, or has been dropped.
15. DO NOT expose the apparatus to dripping and splashing. DO NOT put objects filled with liquids, such as vases, on the apparatus.
16. The MAINS plug or an appliance coupler shall remain readily operable.
17. The airborne noise of the Apparatus does not exceed 70dB (A).
18. Apparatus with CLASS I construction shall be connected to a MAINS socket outlet with a protective earthing connection.
19. To reduce the risk of fire or electric shock, do not expose this apparatus to rain or moisture.
20. Do not attempt to modify this product. Doing so could result in personal injury and/or product failure.
21. Operate this product within its specified operating temperature range.
22. Follow local regulations and consult qualified personnel if the product installation or relocation requires construction work. Choose mounting hardware and an installation location that can support the weight of the product. Avoid locations subject to constant vibration. Use the required tools to install the product properly. Inspect the product periodically.
23. If your product has a feature to log in, upon first time start up, you must change your password.
24. Installation of equipment within an air-handling space (plenum) must be according to local regulations. Consult with qualified personnel to ensure appropriate installation methods for parts or ancillary equipment such as cables that may not be rated for plenum spaces.

**WARNING:**

- Voltages in this equipment are hazardous to life. No user-serviceable parts inside. Refer all servicing to qualified service personnel. The safety certifications do not apply when the operating voltage is changed from the factory setting.
  - If water or other foreign objects enter the inside of the device, fire or electric shock may result.
1. Use only AC adapter that is provided with your product.
  2. If this product is powered by an AC adapter other than the AC adapter that comes with your product, it could result in personal injury and/or product failure.

## Important Product Regulatory Information

EMC conformance testing is based on the use of supplied and recommended cable types. The use of other cable types may degrade EMC performance.

### CE Notice

Hereby, Shure Incorporated declares that this product with CE Marking has been determined to be in compliance with European Union requirements.

The full text of the EU declaration of conformity is available at the following site: <https://www.shure.com/en-EU/support/declarations-of-conformity>.

## UKCA Notice

Hereby, Shure Incorporated declares that this product with UKCA Marking has been determined to be in compliance with UK-CA requirements.

The full text of the UK declaration of conformity is available at the following site: <https://www.shure.com/en-GB/support/declarations-of-conformity>.

## Cybersecurity STATEMENT OF COMPLIANCE

**Product Type:** Relevant connectable products defined as internet-connectable products or network-connectable products, in line with inter alia Product Security and Telecommunications Infrastructure Act 2022.

**Manufacturer Statement:** We, Shure Incorporated, certify and declare as manufacturer under our sole responsibility, that the above-mentioned product(s) conform(s) to the legislation as mentioned under Attachment 1 – to Cybersecurity Statement of Compliance listed here: <https://www.shure.com/en-GB/about-us/security>.

**Information on how to report security issues:** The latest version of Shure's Disclosure policy can be found at the following link: <https://www.shure.com/en-GB/about-us/security>

**Security update periods:** Shure provides support regarding hardware and software updates that continue the integral cyber security safety of Shure products up to 24 months after end of life (AEOL). For the full statement regarding Shure's product support policy, and information regarding products end of life status information can be found at the following link: <https://www.shure.com/en-GB/about-us/security>

**Manufacturer:**

Shure Incorporated 5800 Touhy Avenue  
Niles, Illinois, 60714-4608 U.S.A. Website: [www.Shure.com](http://www.Shure.com).

**Technical documentation is kept at:**

Shure Incorporated, Corporate Global Compliance Engineering Division

**UK Importer/Representative:**

Shure UK Limited  
Unit 2, The IO Centre, Lea Road, Waltham Abbey, Essex, EN9 1AS, U.K.  
Phone: +44 (0)1992 - 703058  
Email: [EMEAsupport@shure.de](mailto:EMEAsupport@shure.de)

**On behalf of Manufacturer:**

Chad Ayers  
08 May 2025 Niles, Illinois  
Senior Director, Global Compliance

## FCC Notice

This equipment has been tested and found to comply with the limits for a Class B digital device pursuant to Part 15 of the FCC Rules. These limits are designed to provide reasonable protection against harmful interference when the equipment is operated in a residential installation. This equipment generates, uses, and can radiate radio frequency energy and, if not installed and used in accordance with the instructions, may cause harmful interference with radio communications. However, there is no guarantee that interference will not occur in a particular installation. If this equipment does cause harmful interference with radio or television reception, which can be determined by turning the equipment off and on, you are encouraged to try to correct the interference by one or more of the following measures:

- Reorient or relocate the antenna of the radio/television receiver.
- Increase the separation between this equipment and the radio/television receiver.
- Plug the equipment into a different outlet so that the equipment and the radio/television receiver are on different power mains branch circuits.
- Consult a representative of Shure or an experienced radio/television technician for additional suggestions.

This device complies with Part 15 of the FCC Rules. Operation is subject to the following two conditions:

1. This device may not cause harmful interference.
2. This device must accept any interference received, including interference that may cause undesired operation.

**Notice:** The FCC regulations provide that changes or modifications not expressly approved by Shure Incorporated could void your authority to operate this equipment.

This equipment complies with FCC radiation exposure limits set forth for an uncontrolled environment. This equipment should be installed and operated with minimum distance 20 cm between the radiator & your body.

For information regarding responsible party and other matters relating to FCC compliance, please contact Shure Incorporated, 5800 W. Touhy Avenue, Niles, Illinois 60714-4608 U.S.A. [shure.com/contact](http://shure.com/contact)

## Canada, ISED Notice

**Notice:** The Industry Canada regulations provide that changes or modifications not expressly approved by Shure Inc. could void your authority to operate this equipment.

This equipment complies with ISED radiation exposure limits set forth for an uncontrolled environment. End user must follow the specific operating instructions for satisfying RF exposure compliance. This transmitter must not be co-located or operating in conjunction with any other antenna or transmitter. The antenna(s) must be installed such that a minimum separation distance of 20 cm is maintained between the radiator (antenna) and all persons at all times.

Cet équipement est conforme aux limites d'exposition aux rayonnements ISED établies pour un environnement non contrôlé. L'utilisateur final doit suivre les instructions spécifiques pour satisfaire les normes. Cet émetteur ne doit pas être co-implanté ou fonctionner en conjonction avec toute autre antenne ou transmetteur. La ou les antennes doivent être installées de telle façon qu'une distance de séparation minimum de 20 cm soit maintenue entre le radiateur (antenne) et toute personne à tout moment.

## Industry Canada (IC) Notices

This device contains licence-exempt transmitter(s)/receiver(s) that comply with Innovation, Science and Economic Development Canada's licence-exempt RSS(s). Operation is subject to the following two conditions:

1. This device may not cause interference.
2. This device must accept any interference, including interference that may cause undesired operation of the device.

L'émetteur/récepteur exempt de licence contenu dans le présent appareil est conforme aux CNR d'Innovation, Sciences et Développement économique Canada applicables aux appareils radio exempts de licence. L'exploitation est autorisée aux deux conditions suivantes :

1. L'appareil ne doit pas produire de brouillage;

2. L'appareil doit accepter tout brouillage radioélectrique subi, même si le brouillage est susceptible d'en compromettre le fonctionnement.

Additional Canadian information on RF exposure also can be found at the following Web address: <http://www.ic.gc.ca/eic/site/smt-gst.nsf/eng/sf08792.html>

## NBTC Notice

เครื่องโทรคมนาคมและอุปกรณ์นี้มีความสอดคล้องตามมาตรฐานหรือข้อกำหนดทางเทคนิคของ กสทช.

## ACMA Notice

WARNING: This device operates under an ACMA class license and must comply with all conditions of that license including operating frequencies.

## SRRC Notice

- (一) 本产品符合“微功率短距离无线电发射设备目录和技术要求”的具体条款和使用场景；
- (二) 不得擅自改变使用场景或使用条件、扩大发射频率范围、加大发射功率（包括额外加装射频功率放大器），不得擅自更改发射天线；
- (三) 不得对其他合法的无线电台（站）产生有害干扰，也不得提出免受有害干扰保护；
- (四) 应当承受辐射射频能量的工业、科学及医疗（ISM）应用设备的干扰或其他合法的无线电台（站）干扰；
- (五) 如对其他合法的无线电台（站）产生有害干扰时，应立即停止使用，并采取措施消除干扰后方可继续使用；
- (六) 在航空器内和依据法律法规、国家有关规定、标准划设的射电天文台、气象雷达站、卫星地球站（含测控、测距、接收、导航站）等军民用无线电台（站）、机场等的电磁环境保护区域内使用微功率设备，应当遵守电磁环境保护及相关行业主管部门的规定。

## IFETEL Notice

La operación de este equipo está sujeta a las siguientes dos condiciones: (1) es posible que este equipo o dispositivo no cause interferencia perjudicial y (2) este equipo o dispositivo debe aceptar cualquier interferencia, incluyendo la que pueda causar su operación no deseada.

## ANATEL Notice

Este equipamento não tem direito à proteção contra interferência prejudicial e não pode causar interferência em sistemas devidamente autorizados. Para maiores informações, consulte o site da ANATEL – <http://www.anatel.gov.br>.

### WARNING:

This device is restricted to indoor use only.

### WARNING:

- the device for operation in the band 5150–5250 MHz is only for indoor use to reduce the potential for harmful interference to co-channel mobile satellite systems;
- for devices with detachable antenna(s), the maximum antenna gain permitted for devices in the bands 5250-5350 MHz and 5470-5725 MHz shall be such that the equipment still complies with the e.i.r.p. limit;
- for devices with detachable antenna(s), the maximum antenna gain permitted for devices in the band 5725-5850 MHz shall be such that the equipment still complies with the e.i.r.p. limits as appropriate; and
- users should also be advised that high-power radars are allocated as primary users (i.e. priority users) of the bands 5250-5350 MHz and 5650-5850 MHz and that these radars could cause interference and/or damage to LE-LAN devices.

## NCC Notice

1. 取得審験證明之低功率射頻器材，非經核准，公司、商號或使用者均不得擅自變更頻率、加大功率或變更原設計之特性及功能。低功率射頻器材之使用不得影響飛航安全及干擾合法通信；經發現有干擾現象時，應立即停用，並改善至無干擾時方得繼續使用。前述合法通信，指依電信管理法規定作業之無線電通信。低功率射頻器材須忍受合法通信或工業、科學及醫療用電波輻射性電機設備之干擾。
2. 應避免影響附近雷達系統之操作。
3. 高增益指向性天線只得應用於固定式點對點系統。

## MIC Notice

### 運用に際しての注意

この機器の使用周波数帯では、電子レンジ等の産業・科学・医療用機器のほか工場の製造ライン等で使用されている移動体識別用の構内無線局（免許を要する無線局）及び特定小電力無線局（免許を要しない無線局）並びにアマチュア無線局（免許を要する無線局）が運用されています。

1. この機器を使用する前に、近くで移動体識別用の構内無線局及び特定小電力無線局並びにアマチュア無線局が運用されていないことを確認して下さい。
2. 万一、この機器から移動体識別用の構内無線局に対して有害な電波干渉の事例が発生した場合には、速やかに使用周波数を変更するか又は電波の発射を停止した上、下記連絡先にご連絡頂き、混信回避のための処置等（例えば、パーティションの設置など）についてご相談して下さい。
3. その他、この機器から移動体識別用の特定小電力無線局あるいはアマチュア無線局に対して有害な電波干渉の事例が発生した場合など何かお困りのことが起きたときは、保証書に記載の販売代理店または購入店へお問い合わせください。代理店および販売店情報は Shure 日本語ウェブサイト <http://www.shure.co.jp> でもご覧いただけます。

日本の電波法および電気通信事業法準拠。本デバイスは日本の電波法および電気通信事業法に基づく認証を受けています。本デバイスを改造しないでください（改造すると認証番号は無効になります）。

本製品が 5GHz 帯で使用するチャンネルは、下記の W52、W53、W56 の 3 タイプです。

タイプ	チャンネル番号	周波数
W52	36	5,180 MHz
	40	5,200 MHz
	44	5,220 MHz
	48	5,240 MHz
W53	52	5,260 MHz
	56	5,280 MHz
	60	5,300 MHz
	64	5,320 MHz
W56	100	5,500 MHz
	104	5,520 MHz
	108	5,540 MHz
	112	5,560 MHz
	116	5,580 MHz

	<b>120</b>	5,600 MHz
	<b>124</b>	5,620 MHz
	<b>128</b>	5,640 MHz
	<b>132</b>	5,660 MHz
	<b>136</b>	5,680 MHz
	<b>140</b>	5,700 MHz

W52 と W53 の帯域の電波は屋内でのみ使用可能です。

現品表示記号について

2.4 OF 4

現品表示記号は、以下のことを表しています。この無線機器は 2.4GHz 帯の電波を使用し、変調方式は「DS-SS」方式および「FH-SS」方式、想定与干渉距離は 40m です。2,400MHz ~ 2,483.5MHz の全帯域を使用し、移動体識別装置の帯域を回避することはできません。

現品表示記号について

2.4 FH 1

現品表示記号は、以下のことを表しています。この無線機器は 2.4GHz 帯の電波を使用し、変調方式は「FH-SS」方式、想定与干渉距離は 10m です。2,400MHz~2,483.5MHz の全帯域を使用し、移動体識別装置の帯域を回避することはできません。

## Waste Electrical and Electronic Equipment (WEEE) Directive



In the European Union and the United Kingdom, this label indicates that this product should not be disposed of with household waste. It should be deposited at an appropriate facility to enable recovery and recycling.

## Registration, Evaluation, Authorization of Chemicals (REACH) Directive

REACH (Registration, Evaluation, Authorization of Chemicals) is the European Union (EU) and the United Kingdom (UK) chemical substances regulatory framework. Information on substances of very high concern contained in Shure products in a concentration above 0.1% weight over weight (w/w) is available upon request.

## US California Perchlorate (for Coin Cell Battery)

This product's coin cell battery may contain perchlorate and may require special handling when recycled or disposed. See [www.dtsc.ca.gov/hazardouswaste/perchlorate](http://www.dtsc.ca.gov/hazardouswaste/perchlorate).

## Recycling Information

Please consider the environment, electric products and packaging are part of regional recycling schemes and do not belong to regular household waste.



AT	BE	BG	CH	CY	CZ	DE	DK	EE	
EL	ES	FI	FR	HR	HU	IE	IS	IT	
LI	LT	LU	LV	MT	NL	NO	PL	PT	
RO	SE	SI	SK	UK(NI)					

## IMXCPU5 Frequency Range and Output Power

Frequency Range	Output Power (Max.)
2402-2480 MHz	9.19 dBm
2412-2472 MHz	17.73 dBm
5150-5250 MHz	19.76 dBm
5250-5350 MHz	19.91 dBm
5725-5850 MHz	12.76 dBm
5945-6425 MHz	19.08 dBm

**Wi-Fi 6E LPI:** Restricted to indoor use only (including trains where metal coated windows are fitted and aircraft). Outdoor use (including in road vehicles) is not permitted.

**Frequency band 5150 – 5250 MHz:** Indoor use: Inside buildings only. Installations and use inside road vehicles and train carriages are not permitted. Limited outdoor use: if used outdoors, equipment shall not be attached to a fixed installation or the external body of road vehicles, a fixed infrastructure or a fixed outdoor antenna. Use by unmanned aircraft system (UAS) is limited to within the 5170 – 5250 MHz band.

**Frequency band 5250 – 5350 MHz:** Indoor use: Inside buildings only. Installations and use in road vehicles, trains and aircraft are not permitted. Outdoor use is not permitted.

**Frequency band 5470 – 5725 MHz:** Installations and use in road vehicles, trains and aircraft and use for unmanned aircraft system (UAS) are not permitted.

## 中国 RoHS

部件名称	有害物质									
	Pb	Cd	Hg	Cr(VI)	PBB	PBDE	DBP	BBP	DIBP	DEHP
电路模块	X	○	○	○	○	○	○	○	○	○
金属模块	X	○	○	○	○	○	○	○	○	○
线缆及其组件	X	○	○	○	○	○	○	○	○	○
电源适配器*	X	○	○	○	○	○	○	○	○	○
锂电池组*	X	○	○	○	○	○	○	○	○	○

注 1: ○: 表示该有害物质在该部件所有均质材料中的含量均不出电器电子产品有害物质限制使用国家标准要求。  
 X: 表示该有害物质至少在该部件某一均质材料中的含量超出电器电子产品有害物质限制使用国家标准要求。  
 注 2: 本产品大部分的部件采用无害的环保材料制造, 含有有害物质的部件皆因全球技术发展水平的限制而无法实现有害物质的替代。  
 注 3: 以上未列出的部分, 表明其有害物质含量均不出电器电子产品有害物质限制使用国家标准要求  
 \*表示如果包含部分

臺灣 RoHS

## 限用物質含有情況標示聲明書

Declaration of the Presence Condition of the Restricted Substances Marking

設備名稱：微型計算機 Equipment name		型號（型式）：IMXCPU5 Type designation (Type)				
單元Unit	限用物質及其化學符號 Restricted substances and its chemical symbols					
	鉛Lead (Pb)	汞Mercury (Hg)	鎘Cadmium (Cd)	六價鉻 Hexavalent chromium (Cr <sup>6+</sup> )	多溴聯苯 Polybrominated biphenyls (PBB)	多溴二苯醚 Polybrominated diphenyl ethers (PBDE)
塑膠外殼	○	○	○	○	○	○
PCB主機板	—	○	○	○	○	○
硬盤	○	○	○	○	○	○
風扇	○	○	○	○	○	○
電源適配器	—	○	○	○	○	○
其他線材	○	○	○	○	○	○
附件	○	○	○	○	○	○

備考1. “超出0.1 wt %”及“超出0.01 wt %”係指限用物質之百分比含量超出百分比含量基準值。  
 Note 1: “Exceeding 0.1 wt %” and “exceeding 0.01 wt %” indicate that the percentage content of the restricted substance exceeds the reference percentage value of presence condition.

備考2. “○”係指該項限用物質之百分比含量未超出百分比含量基準值。  
 Note 2: “○” indicates that the percentage content of the restricted substance does not exceed the percentage of reference value of presence.

備考3. “—”係指該項限用物質為排除項目。  
 Note 3: The “—” indicates that the restricted substance corresponds to the exemption.

FCC / IC ID

Contains FCC ID: PD9AX210NG

Contains IC: 100M-AX210NG